

rotork®

Keeping the World Flowing

Air Preparation

Regulators, Pressure Regulators, Lubricators and Accessories



MIDLAND-ACS
A rotork® Brand

Contents

Section	Page	Section	Page
Introduction	3	3575 Series air service units	29
3550 Series air service units	4	Filter Regulators	29
Filter Regulators	4	Filters	31
Filters	8	Pressure Regulators	33
Pressure Regulators	11	Over Pressurisation Device	35
Accessories	13	Features and Benefits	35
3500 Series air service units	15	General Description	36
Filter Regulators	15	Development	36
Filters	18	Performance Characteristics	37
Pressure Regulators	22	Rotork in the Oil and Gas Industries	39
Lubricator	24		
Accessories	26		



Rotork is the global market leader in valve automation and flow control. Our products and services are helping organisations around the world to improve efficiency, assure safety and protect the environment.

We strive always for technical excellence, innovation and the highest quality standards in everything we do. As a result, our people and products remain at the forefront of flow control technology.

Uncompromising reliability is a feature of our entire product range, from our flagship electric actuator range through to our pneumatic, hydraulic and electro-hydraulic actuators, as well as instruments, gearboxes and valve accessories.

Rotork is committed to providing first class support to each client throughout the whole life of their plant, from initial site surveys to installation, maintenance, audits and repair. From our network of national and international offices, our engineers work around the clock to maintain our position of trust.

Rotork. Keeping the world flowing.

Introduction

As a specialist manufacturer of stainless steel large flow air service equipment we offer comprehensive, purpose designed, engineered and manufactured solutions for filtration and regulation of compressed air and gases for the actuation industries.



Certification Options Available



3550 Series air service units – 1/4" to 3/4" Filter Regulators

A 316L stainless steel combined unit for filtration and regulation of compressed air and gases for the actuation industries.

Features and Benefits

- Specifically designed for severe environments
- Non or self-relieving
- 40 micron element stainless steel 316 as standard, 5 micron option available
- 316L stainless steel construction
- Regulated pressure range from 0.50 to 12.0 bar depending on model selection
- Large flow characteristics
- NACE: standard temperature and manual drain only

Media & Ambient Temperature Range

- Standard temperature
-20 to + 80 °C (-4 to +176 °F)
- Low temperature version
-50 to +80 °C (-58 to +176 °F)

Note: When product is ordered as ATEX ambient temperature is limited to +40 °C (104 °F) Ex II 2G c T6.

Maximum Relief Flow

- At 2 bar (29 psi) secondary pressure
0.5 cc/sec (0.03 cu in/sec)

Flow

At 10 bar (145 psi) supply pressure, 6 bar (87 psi) secondary pressure, 1 bar (14.5 psi) pressure drop.

- 1/4" - 3,720 l/min (130 SCFM)
- 1/2" and 3/4" - 6,000 l/min (212 SCFM)

Maximum Inlet Pressure

- Manual drain - 20 bar (290 psi)
- Automatic drain - 17 bar (247 psi)

Ports NPT

(BSP option available - consult factory for part codes)

- 1/4", 1/2", 3/4"

Gauge Ports

- 1/8" NPT
- 1/4" NPT (option available - suffix product code with 'X')

Certification Options Available



Relief Vent Port

- 1/8" NPT (fitted with breather)
Note: Not fitted on low temperature option

Bowl Capacity

- 21 cc (1.28 cu ins)

Accessories Available

- Mounting brackets
- Stainless steel pressure gauge
- Hand wheel

See page 13-14 for ordering details

Operating Media

- Air, inert gas and sweet (natural) gas
- Sour gas (NACE) standard temperature and manual drain only
- Suitable for water and other compatible liquids - manual drain only, consult Rotork Midland for details

Note: To prevent freezing of the condensate within the product, the media dew point must be at least 10 °C below the lowest ambient temperature the product will be exposed to.

Construction Materials

- Body/bonnet/bowl: 316L stainless steel
- Internals: 316L stainless steel and Ryton R-4
Note: on auto-drain version float is nylon, polyoxymethylene and rubber.
- Element: 40 micron 316 stainless steel
(5 micron option available - suffix product code with '05')
- Seals: Standard option - Fluoroelastomer
Low temperature option - EPDM¹ and Fluorosilicone

¹ The use of lubrication upstream of the product is not recommended for low temperature applications

3550 Series air service units – 1/4" to 3/4" Filter Regulators - Engineering drawings (manual drain)

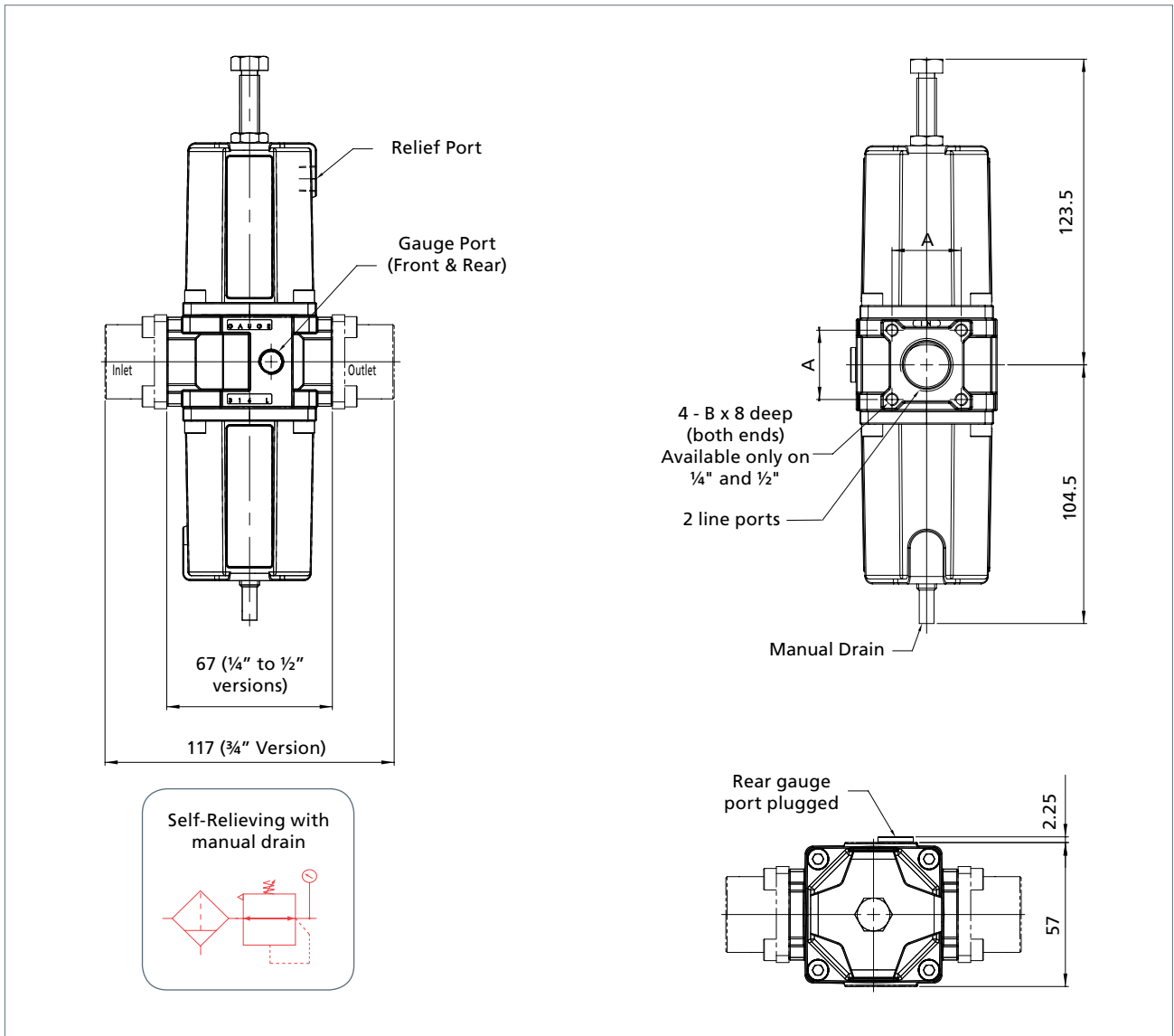

Size	Filter	Regulated Pressure bar (psi)	Max Inlet Pressure bar	A	B	Weight kg	Cv
1/4"	Manual Drain	0.50 to 2.0 (7.2 to 29)	20	24	M4	1.75	2.4
1/2"				28	M5	1.75	4.4
3/4"				-	-	1.95	5.0
1/4"	Manual Drain	0.50 to 4.0 (7.2 to 58)	20	24	M4	1.75	2.4
1/2"				28	M5	1.75	4.4
3/4"				-	-	1.95	5.0
1/4"	Manual Drain	0.50 to 8.0 (7.2 to 116)	20	24	M4	1.75	2.4
1/2"				28	M5	1.75	4.4
3/4"				-	-	1.95	5.0
1/4"	Manual Drain	0.50 to 12.0 (7.2 to 174)	20	24	M4	1.75	2.4
1/2"				28	M5	1.75	4.4
3/4"				-	-	1.95	5.0

3550 Series air service units – 1/4" to 3/4" Filter Regulators - Engineering Drawings (auto drain)

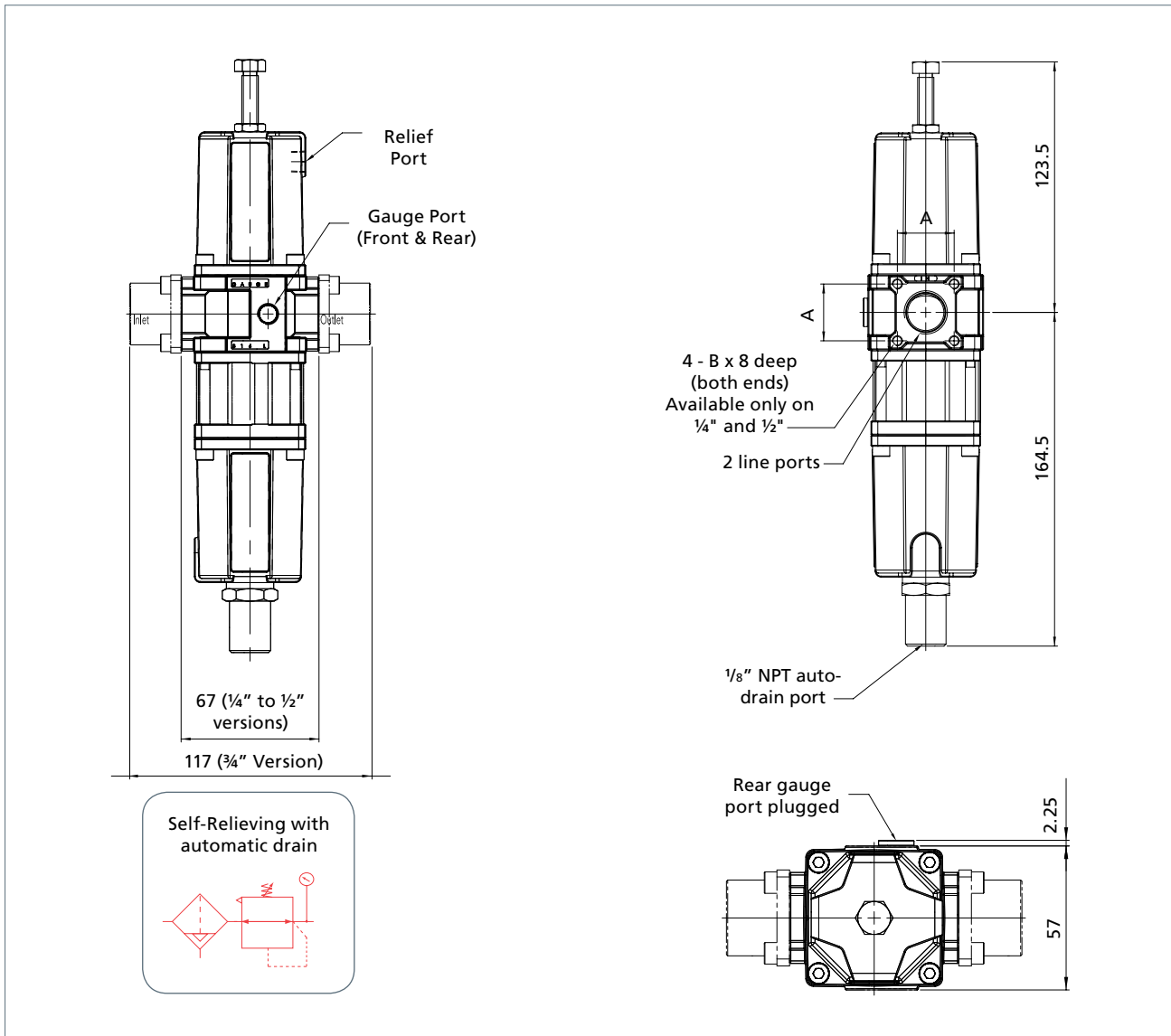

Size	Filter	Regulated Pressure bar (psi)	Max Inlet Pressure bar	A	B	Weight kg	Cv
1/4"	Auto Drain	0.50 to 2.0 (7.2 to 29)	17	24	M4	2.05	2.4
1/2"				28	M5	2.05	4.4
3/4"				-	-	2.25	5.0
1/4"	Auto Drain	0.50 to 4.0 (7.2 to 58)	17	24	M4	2.05	2.4
1/2"				28	M5	2.05	4.4
3/4"				-	-	2.25	5.0
1/4"	Auto Drain	0.50 to 8.0 (7.2 to 116)	17	24	M4	2.05	2.4
1/2"				28	M5	2.05	4.4
3/4"				-	-	2.25	5.0
1/4"	Auto Drain	0.50 to 12.0 (7.2 to 174)	17	24	M4	2.05	2.4
1/2"				28	M5	2.05	4.4
3/4"				-	-	-	-

3550 Series air service units – 1/4" to 3/4" Filter Regulator - Flow Characteristics

3550 Series Coding Chart - Filter Regulators

Additional Options

Size		Type ¹		Material		Seals °C (°F)		Regulated Pressure bar (psi)		Port Style		Revision	Filter Element (40 micron standard)		Gauge Port		Approval	
2	1/4"	FRM	Manual Drain	S	Stainless	V	Standard -20 (-4)	02	2 (29)	1	BSP	A	05	5 micron	X	1/4" NPT Gauge Port	/ATEX	II 2G c T6
4	1/2"	FRA ¹	Auto Drain			F ²	Low Temp -50 (-58)	04	4 (58)	2	NPT			w/o option		w/o option		w/o option
6	3/4"	FRN	Manual Drain Non Relieving					08	8 (116)									
		FRB ¹	Auto Drain Non Relieving					12	12 (174)									
●		●		S		●		●		●		A	●		●		●	

¹ NACE not available in auto-drain or low temperature options

² Low temperature option not available in auto-drain

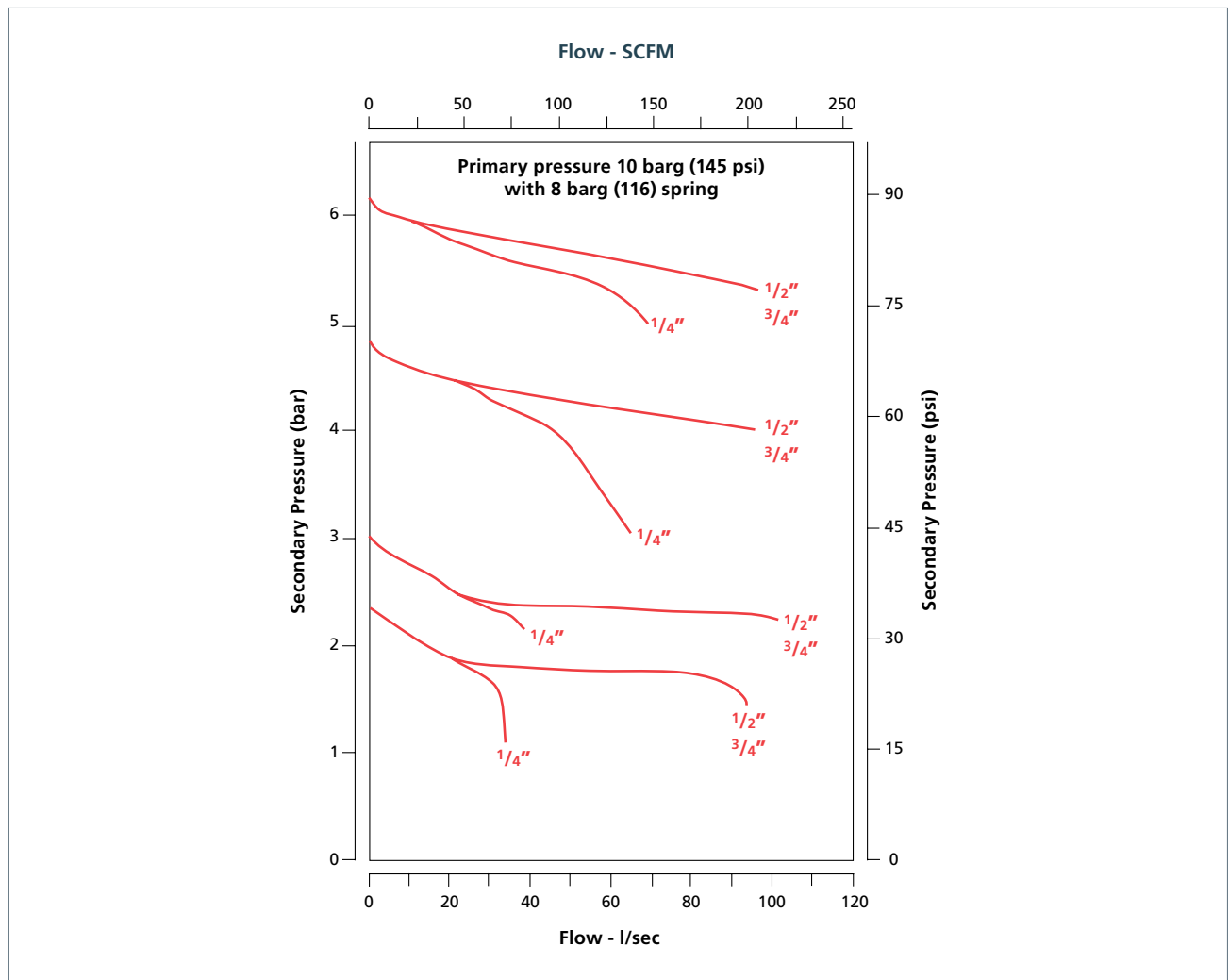

3550 Series air service units – ¼" to ¾" Filters

A 316L stainless steel unit for filtration of compressed air and gases for the actuation industries.

Features and Benefits

- Specifically designed for severe environments
- 40 micron element stainless steel 316 as standard, 5 micron option available
- 316L stainless steel construction
- Large flow characteristics
- NACE: standard temperature and manual drain only

Media & Ambient Temperature Range

- Standard temperature
-20 to +80 °C (-4 to +176 °F)
- Low temperature version
-50 to +80 °C (-58 to +176 °F)

Note: When product is ordered as /ATEX ambient temperature is limited to +40 °C (104 °F) Ex II 2G c T6.

Maximum Inlet Pressure

- Manual drain - 20 bar (290 psi)
- Automatic drain - 17 bar (247 psi)

Flow

At 7 bar (102 psi) supply pressure, 0.35 bar (5 psi) pressure drop.

- ¼" - 1,380 l/min (49 SCFM)
- ½" and ¾" - 2,940 l/min (104 SCFM)

Ports NPT

(BSP option available - consult factory for part codes)

- ¼", ½", ¾"

Automatic Drain Port

- ⅛" NPT

Bowl Capacity

- 21 cc (1.28 cu ins)

Accessories Available

- Mounting brackets

See page 13 for ordering details

Certification Options Available



Operating Media

- Air, inert gas and sweet (natural) gas
- Sour gas (NACE) standard temperature and manual drain only
- Suitable for water and other compatible liquids - manual drain only, consult Rotork Midland for details

Note: To prevent freezing of the condensate within the product, the media dew point must be at least 10°C below the lowest ambient temperature the product will be exposed to.

Construction Materials

- Body/bonnet/bowl and internals: 316L stainless steel and Ryton R-4
Note: on auto-drain version float is nylon, polyoxymethylene and rubber.
- Element: 40 micron 316 stainless steel (5 micron option available - suffix product code with '05')
- Seals: Standard option - Fluoroelastomer
Low temperature option - EPDM and Fluorosilicone¹

¹ The use of lubrication upstream of the product is not recommended for low temperature applications.

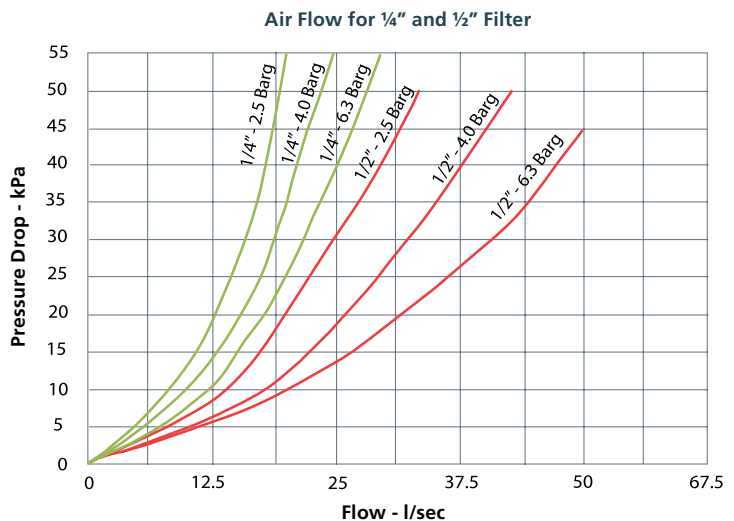

3550 Series air service units – 1/4" to 3/4" Filters - Engineering Drawings (manual drain)

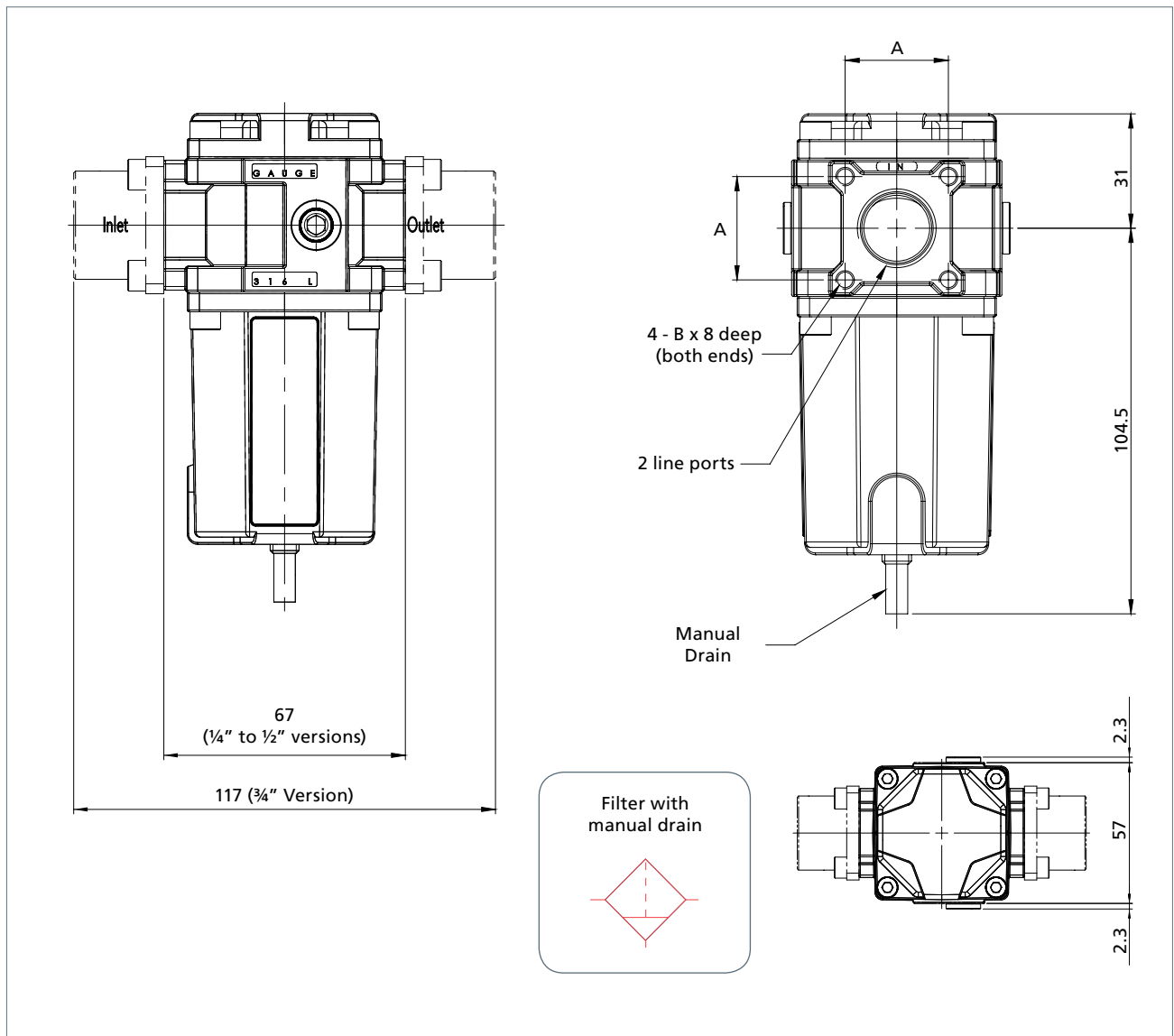

Size	Filter	Max Inlet Pressure bar	A	B	Weight kg	Cv
1/4"	Manual Drain	20	24	M4	1.3	2.4
1/2"			28	M5	1.3	4.4
3/4"			-	-	1.5	5.0

3550 Series air service units – ¼" to ¾" Filters - Engineering Drawings (auto drain)

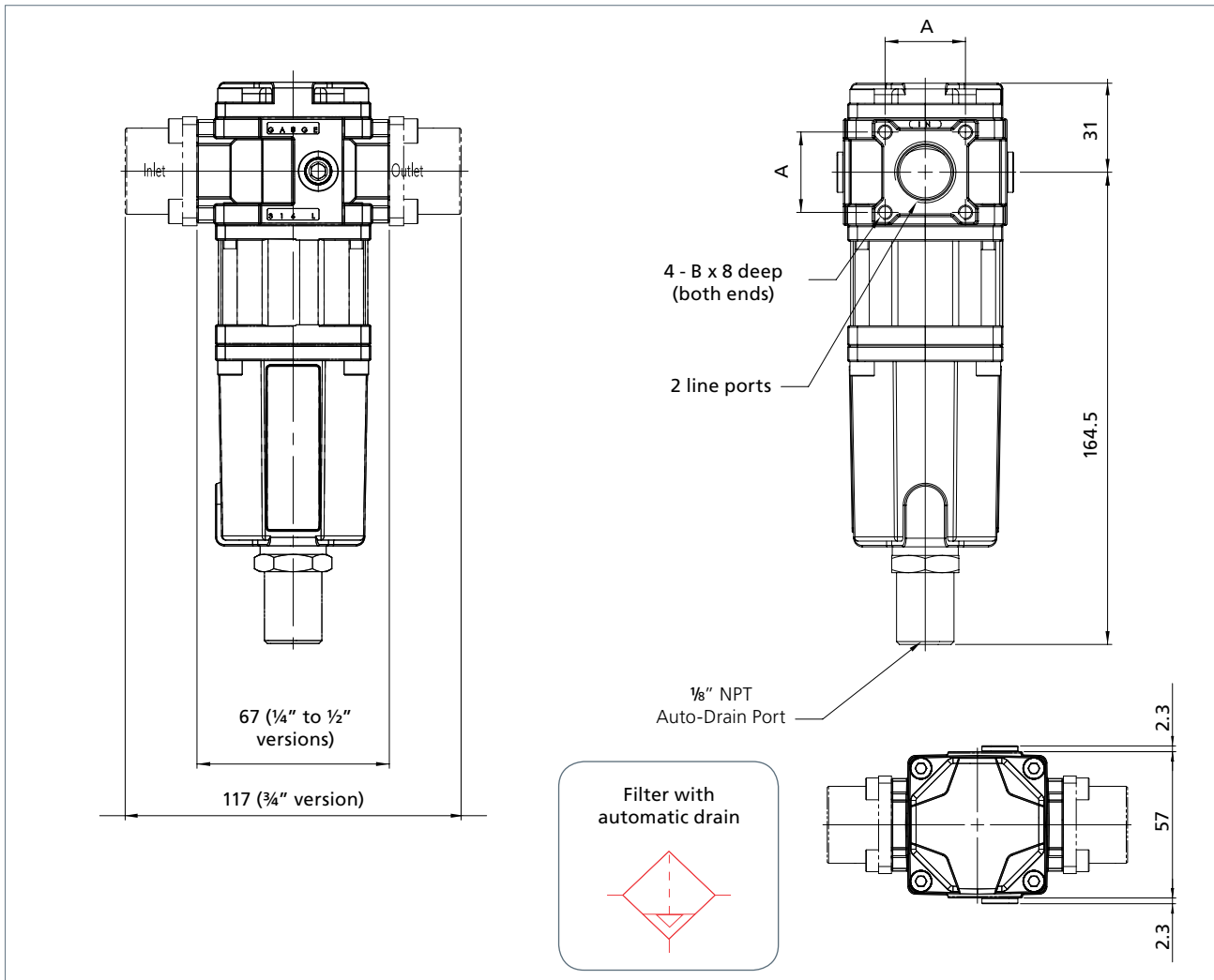

Size	Filter	Max Inlet Pressure bar	A	B	Weight kg	Cv
¼"	Auto Drain	17	24	M4	1.6	2.4
½"			28	M5	1.6	4.4
¾"			-	-	1.8	5.0

3550 Series Coding Chart - Filters

Additional Options

Size		Type ¹		Material		Seals °C (°F)		Max Inlet Pressure bar (psi)		Port Style		Revision	Filter Element (40 micron standard)		Approval	
2	¼"	FLM	Manual Drain	S	Stainless	V	Standard -20 (-4)	17	17 (247) (FLA only)	1	BSP	A	05	5 micron	/ATEX	II 2G c T6
4	½"	FLA ¹	Auto Drain			F ²	Low Temp -50 (-58)	20	20 (290) (FLM only)	2	NPT			w/o option		w/o option
6	¾"															
●		●		S		●		●		●		A	●		●	

¹ NACE not available in auto-drain or low temperature options

² Low temperature option not available in auto-drain

3550 Series air service units – 1/4" to 3/4" Pressure Regulators

A 316L stainless steel unit for the pressure regulation of compressed air and gases for the actuation industries.

Features and Benefits

- Specifically designed for severe environments
- Non or self-relieving
- 316L stainless steel construction
- Large flow characteristics
- NACE: standard temperature only

Media & Ambient Temperature Range

- Standard temperature
-20 to +80 °C (-4 to +176 °F)
- Low temperature version
-50 to +80 °C (-58 to +176 °F)

Note: When product is ordered as /ATEX ambient temperature is limited to +40 °C (104 °F) Ex II 2G c T6.

Maximum Relief Flow

- At 2 bar (29 psi) secondary pressure
0.5 cc/sec (0.03 cu in/sec)

Flow

At 10 bar (145 psi) inlet pressure, 6 bar (87 psi) secondary pressure with 1 bar (14.5 psi) pressure drop.

- 1/4" - 3,780 l/min (133 SCFM)
- 1/2" and 3/4" - 6,180 l/min (218 SCFM)

Ports NPT

(BSP option available - consult factory for part codes)

- 1/4", 1/2", 3/4"

Gauge Ports

- 1/8" NPT
- 1/4" NPT (option available - suffix product code with 'X')

Relief Vent Port

- 1/8" NPT (fitted with breather)
- Note: Not fitted on low temperature option

Accessories Available

- Mounting brackets
- Stainless steel pressure gauge
- Hand wheel

See page 13-14 for ordering details

Certification Options Available



Operating Media

- Air, inert gas and sweet (natural) gas
- Sour gas (NACE) standard temperature only
- Suitable for water and other compatible liquids, consult Rotork Midland for detail

Note: To prevent freezing of the condensate within the product, the media dew point must be at least 10 °C below the lowest ambient temperature the product will be exposed to.

Construction Materials

- Body/bonnet/bowl and internals:
316L stainless steel and Ryton R-4
- Seals: Standard option - Fluoroelastomer
Low temperature option - EPDM and Fluorosilicone¹

¹ The use of lubrication upstream of the product is not recommended for low temperature applications.

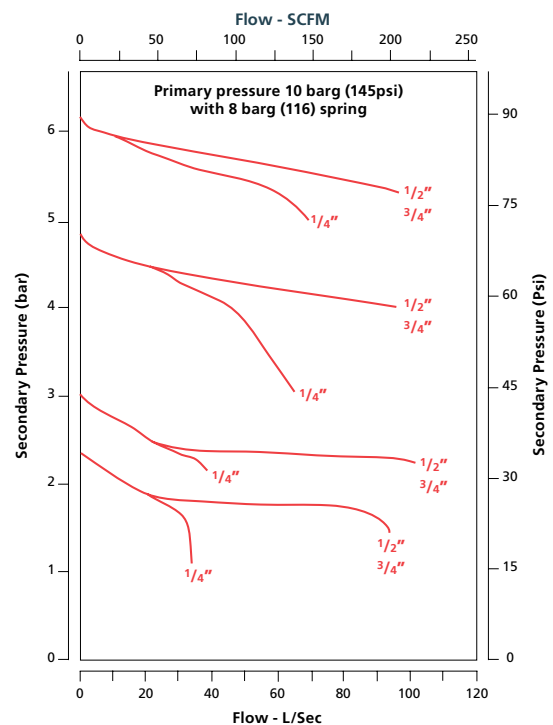

3550 Series air service units – 1/4" to 3/4" Pressure Regulators - Engineering Drawings

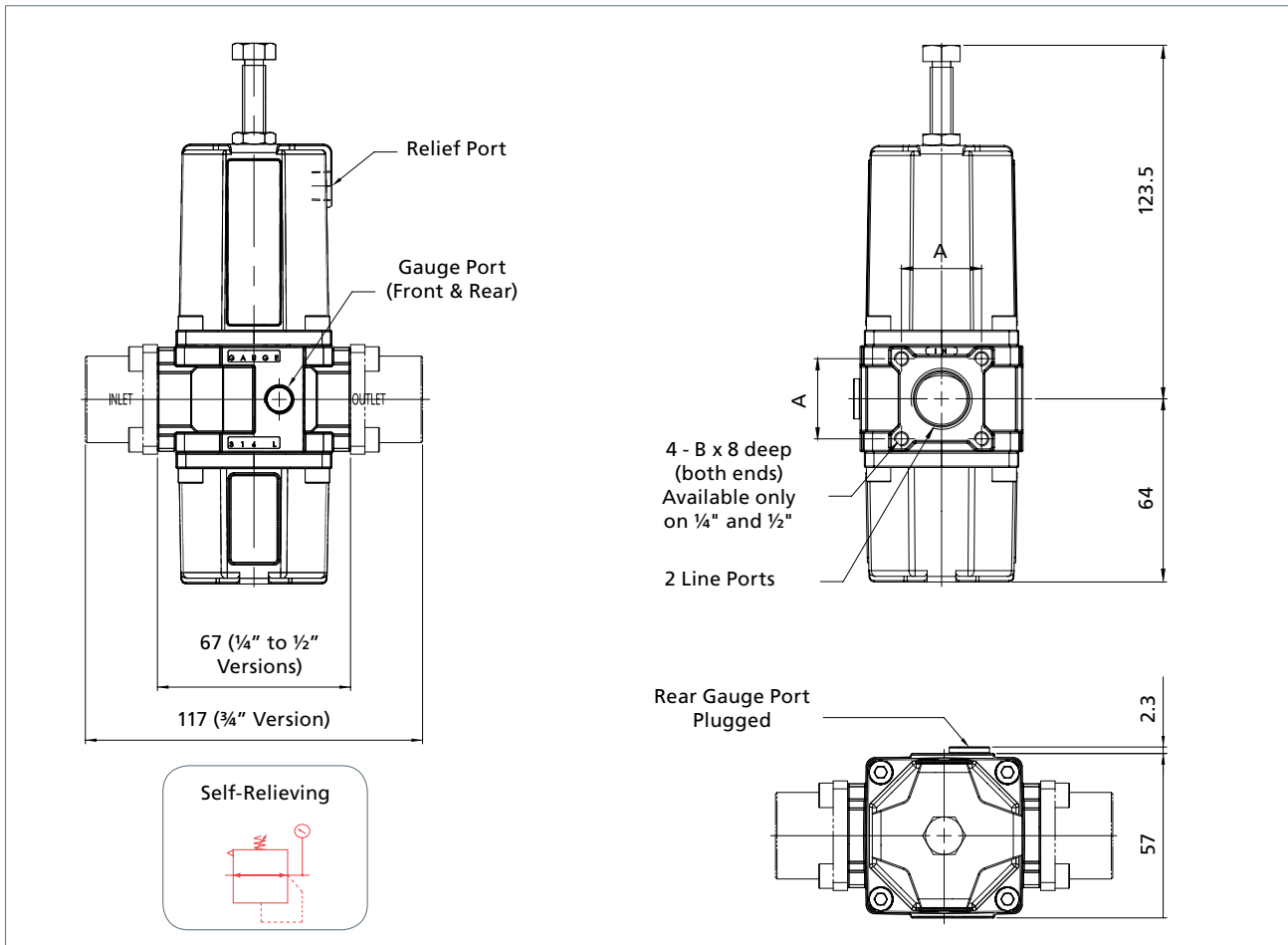

Size	Regulated Pressure bar (psi)	Max Inlet Pressure bar	A	B	Weight kg	Cv
1/4"	0.50 to 2.0 (7.2 to 29)	20	24	M4	1.6	2.4
1/2"			28	M5	1.6	4.4
3/4"			---	---	1.8	5.0
1/4"	0.50 to 4.0 (7.2 to 58)	20	24	M4	1.6	2.4
1/2"			28	M5	1.6	4.4
3/4"			---	---	1.8	5.0
1/4"	0.50 to 8.0 (7.2 to 116)	20	24	M4	1.6	2.4
1/2"			28	M5	1.6	4.4
3/4"			---	---	1.8	5.0
1/4"	0.50 to 12.0 (7.2 to 174)	20	24	M4	1.6	2.4
1/2"			28	M5	1.6	4.4
3/4"			---	---	1.8	5.0

3550 Series Coding Chart - Pressure Regulators

Size		Type		Material		Seals °C (°F)		Regulated Pressure bar (psi)		Port Style		Revision	Gauge Port	Approval
2	1/4"	PRV	Self Relieving	S	Stainless	V	Standard -20 (-4)	02	2 (29)	1	BSP	A	X 1/4" NPT Gauge Port	/ATEX Ex II 2G c T6
4	1/2"	PRN	Non Relieving			F ¹	Low Temp -50 (-58)	04	4 (58)	2	NPT		w/o option	w/o option
6	3/4"							08	8 (116)					
								12	12 (174)					

Additional Options

¹ NACE not available in low-temperature options

3550 Series air service units – Accessories for 1/4" to 3/4" units - supplied separately

Plastic handwheel kit

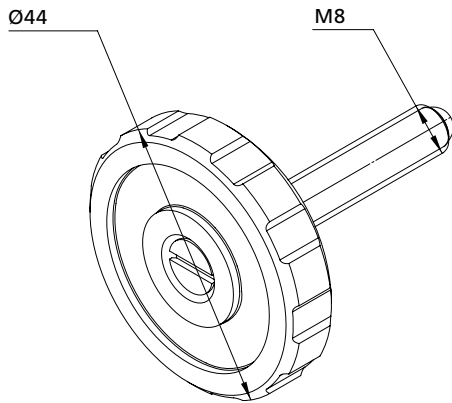

Product Code	Description
SSAF238/23	Kit comprises of 1 plastic handwheel, 1 pressure adjusting screw (316 stainless steel) and 1 hand-wheel retaining screw (316 stainless steel)

Stud mounting kit

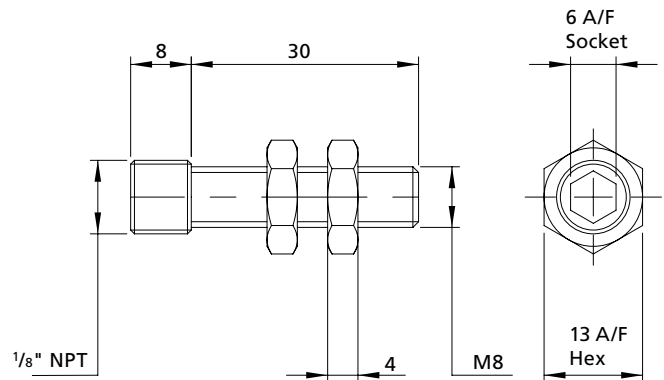

Product Code	Description
SSBF238/21	Kit comprises of 1 stud complete with 2 locknuts and is designed to screw into un-used gauge port. All components 316 stainless steel.

Mounting bracket

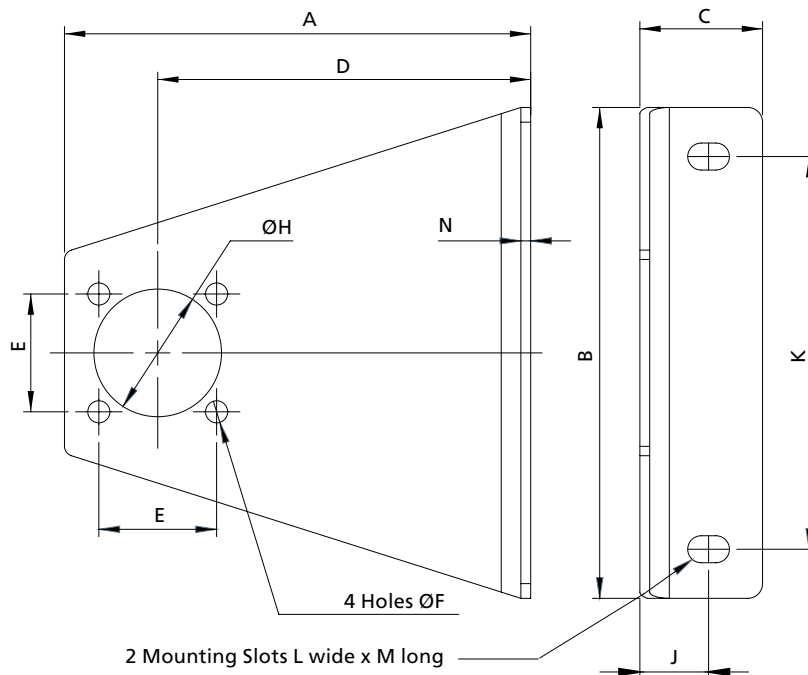

Product Code	Suitable for	A	B	C	D	E	F	H	J	K	L	M	N
SSF2110-7S	1/4" units (Short)	79	100	25	60	24	4.5	26	14	80	5.5	8.5	2
SSF2110-7	1/4" units (Long)	95	100	25	76	24	4.5	26	14	80	5.5	8.5	2
SSF4110-7	1/2", 3/4" units	95	100	25	76	28	4.5	26	14	80	5.5	8.5	2

Component material 316 stainless steel. Brackets are supplied complete with fasteners.
 Note: Part numbers above are for single items

3550 Series air service units – Accessories for 1/4" to 3/4" units - supplied separately

Pressure gauge SS-316L - Glycerine filled

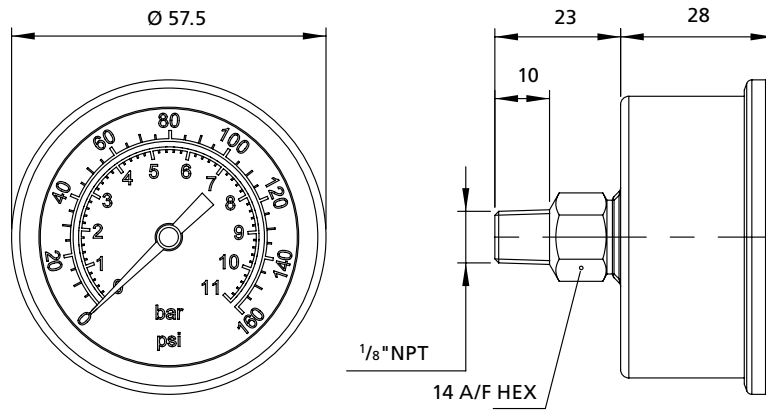

Product Code	Size mm	Regulated Pressure bar
SSF153N/2GLY	50	0 to 2
SSF153N/4GLY	50	0 to 4
SSF153N/11GLY	50	0 to 11

Please consult factory for low temperature version if required.

Tamperproof cap kit

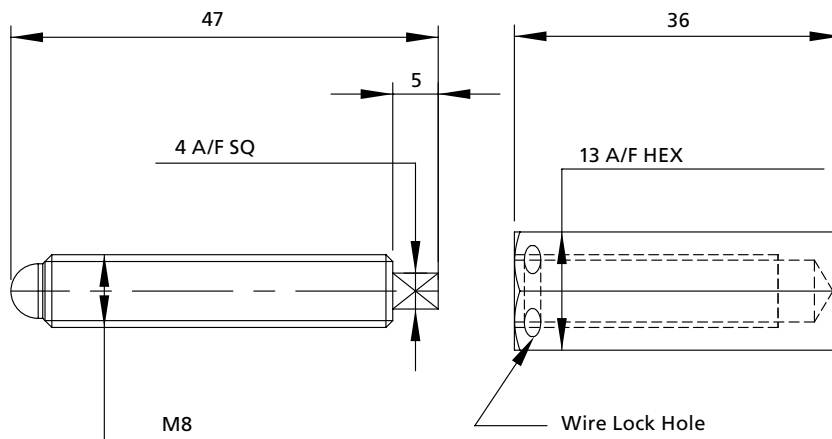

Product Code	Description
SSAF238/22	Kit comprises of 1 pressure adjusting screw and 1 tamperproof cap. All material 316 stainless steel

3500 Series air service units – ¾" to 1" Filter Regulators

A 316L stainless steel combined unit for filtration and regulation of compressed air and gases for the actuation industries.

Features and Benefits

- Specifically designed for severe environments
- 40 micron element as standard, 5 micron option available
- Non or self-relieving
- 316L stainless steel construction
- Large flow characteristics
- Bowl capacity window

Media & Ambient Temperature Range

- Standard temperature
-20 to + 80 °C (-4 to +176 °F)
- Low temperature version
-50 to +80 °C (-58 to +176 °F)

Note: When product is ordered as /ATEX ambient temperature is limited to +40 °C (104 °F) Ex II 2G c T6.

Maximum Relief Flow

- At 2 bar (29 psi) secondary pressure
0.5 cc/sec (0.03 cu in/sec)

Flow

At 7 bar (102 psi) supply pressure, 6 bar (87 psi) secondary pressure, 1 bar (14.5 psi) pressure drop.

- 7,800 l/min (274 SCFM)

Maximum Inlet Pressure

- Manual drain - 20 bar (290 psi)
- Automatic drain - 17 bar (247 psi)

Ports NPT

(BSP option available - consult factory for part codes)

- ¾", 1"

Gauge Ports

- 1/8" NPT

Relief Vent Port

- 1/8" NPT (fitted with breather)

Note: Not fitted on low temperature option



Bowl Capacity

- 260 cc (15.87 cu ins)

Accessories Available

- Mounting brackets
- Stainless steel pressure gauge

See page 26-28 for ordering details

Operating Media

- Gases - air, inert gas and sweet (natural) gases

Note: To prevent freezing of the condensate within the product, the media dew point must be at least 10 °C below the lowest ambient temperature the product will be exposed to.

Construction Materials

- Body/bonnet/bowl and internals: 316L stainless steel
Note: on auto-drain version float is nylon, polyoxymethylene and rubber.
- Element: 40 micron sintered polypropylene (5 micron option available - suffix product code with '05')
- Seals: Standard option - Fluoroelastomer
Low temperature option - EPDM and Fluorosilicone¹

¹ The use of lubrication upstream of the product is not recommended for low temperature applications.

Certification Options Available



3500 Series air service units – 3/4" to 1" Filter Regulators - Engineering Drawings (manual drain)

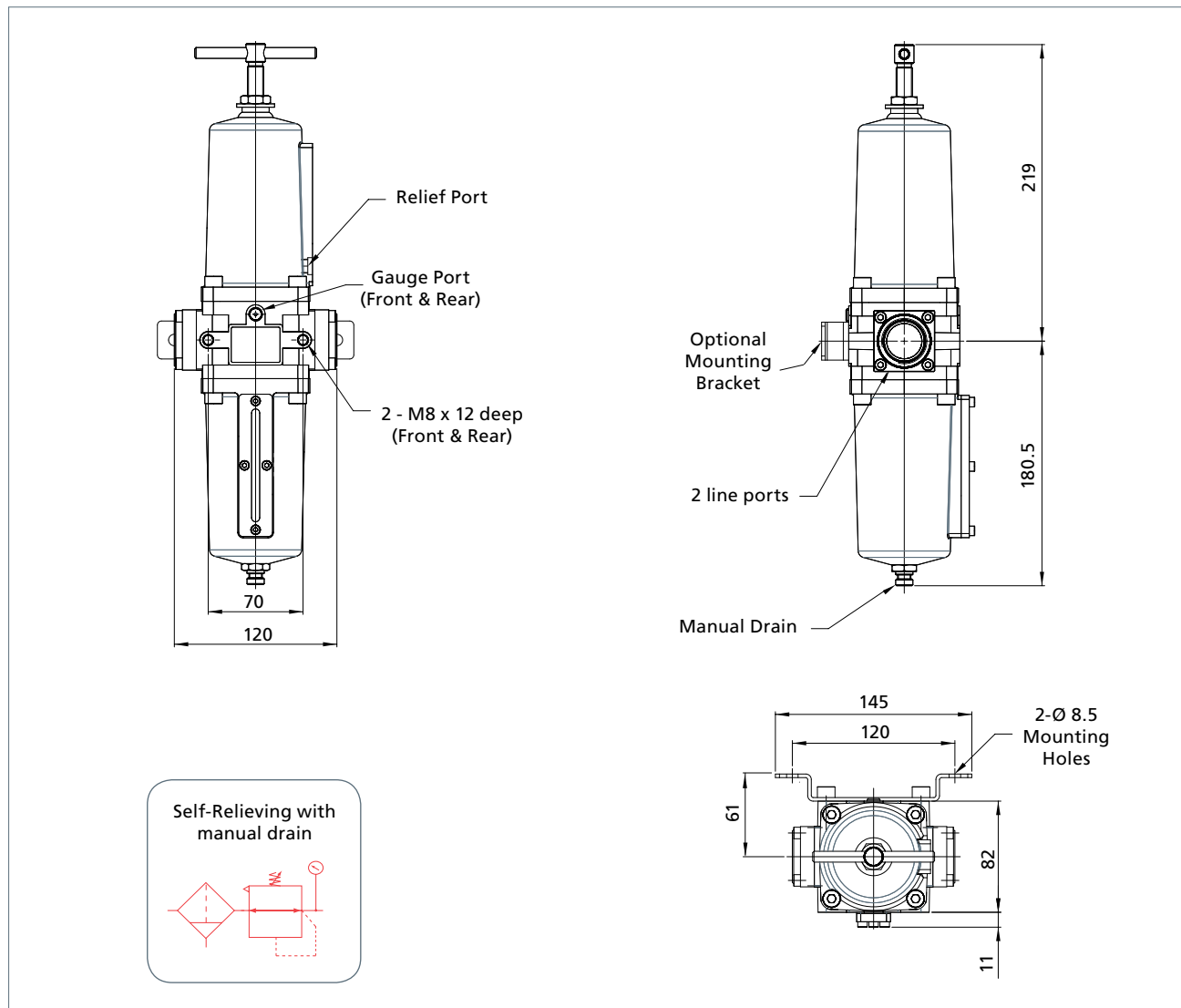

Size	Filter	Regulated Pressure bar (psi)	Max Inlet Pressure bar	Weight kg	Cv
3/4"	Manual Drain	0.50 to 2.0	20	5.75	6.5
1"		(7.2 to 29)		5.75	8.8
3/4"	Manual Drain	0.50 to 4.0	20	5.75	6.5
1"		(7.2 to 58)		5.75	8.8
3/4"	Manual Drain	0.50 to 7.0	20	5.75	6.5
1"		(7.2 to 102)		5.75	8.8
3/4"	Manual Drain	0.50 to 10.0	20	5.75	6.5
		(7.2 to 145)			

3500 Series air service units – 3/4" to 1" Filter Regulators - Engineering Drawings (auto drain)

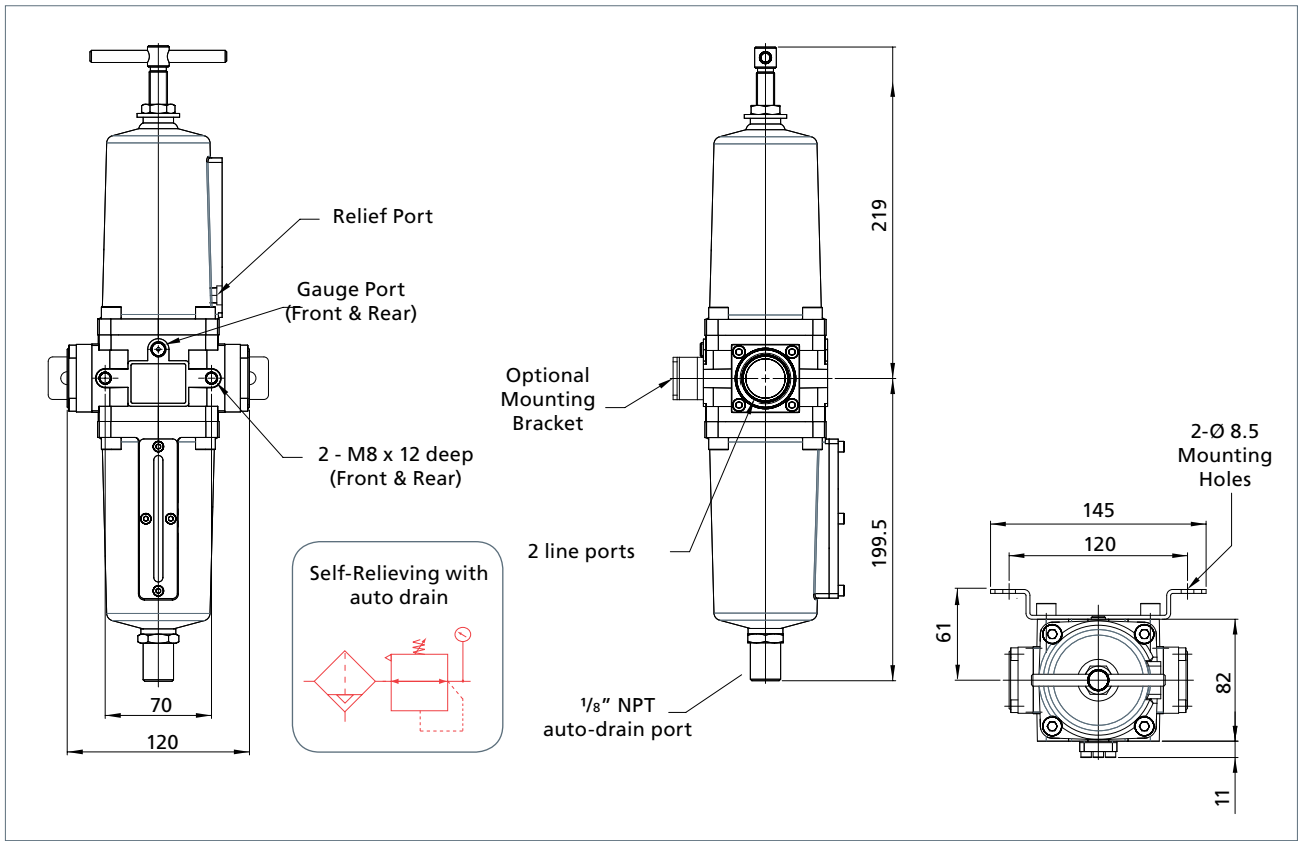

Size	Filter	Regulated Pressure bar (psi)	Max Inlet Pressure bar	Weight kg	Cv
3/4"	Auto Drain	0.50 to 2.0 (7.2 to 29)	17	5.75	6.5
1"				5.75	8.8
3/4"	Auto Drain	0.50 to 4.0 (7.2 to 58)	17	5.75	6.5
1"				5.75	8.8
3/4"	Auto Drain	0.50 to 7.0 (7.2 to 102)	17	5.75	6.5
1"				5.75	8.8
3/4"	Auto Drain	0.50 to 10.0 (7.2 to 145)	17	5.75	6.5
1"				5.75	8.8

3500 Series Coding Chart - Filter Regulators

Size		Type		Material		Seals °C (°F)		Regulated Pressure bar (psi)		Port Style		Filter Element (40 micron standard)		Approval	
6	3/4"	FRM	Manual Drain	S	Stainless	V	Standard -20 (-4)	02	2 (29)	1	BSP	05	5 micron	/ATEX	Ex II 2G c T6
8	1"	FRA	Auto Drain			L ¹	Low Temp -50 (-58)	04	4 (58)	2	NPT		w/o option		w/o option
		FRN	Manual Drain Non Relieving					07	7 (102)						
		FRB	Auto Drain Non Relieving					10	10 (145)						
●		●		S		●		●		●		●		●	

¹ Low temperature version not available in auto-drain

Additional Options

3500 Series air service units – 3/4" to 1" Filters

A 316L stainless steel unit for filtration of compressed air and gases for the actuation industries.

Features and Benefits

- Specifically designed for severe environments
- 40 micron element as standard, 5 micron option available
- 316L stainless steel construction
- Large flow characteristics
- Bowl capacity window

Media & Ambient Temperature Range

- Standard temperature
-20 to +80 °C (-4 to +176 °F)
- Low temperature version
-50 to +80 °C (-58 to +176 °F)

Note: When product is ordered as /ATEX ambient temperature is limited to +40 °C (104 °F) Ex II 2G c T6.

Flow

At 7 bar (102 psi) supply pressure, 0.35 bar (5 psi) pressure drop.

- 10,020 l/min (353 SCFM)

Maximum Inlet Pressure

- Manual drain - 20 bar (290 psi)
- Automatic drain - 17 bar (247 psi)

Ports NPT

(BSP option available - consult factory for part codes)

- 3/4", 1"

Bowl Capacity

- 260 cc (15.87 cu ins)

Operating Media

- Gases - air, inert gas and sweet (natural) gas

NOTE: To prevent freezing of the condensate within the product, the media dew point must be at least 10 °C below the lowest ambient temperature the product will be exposed to.

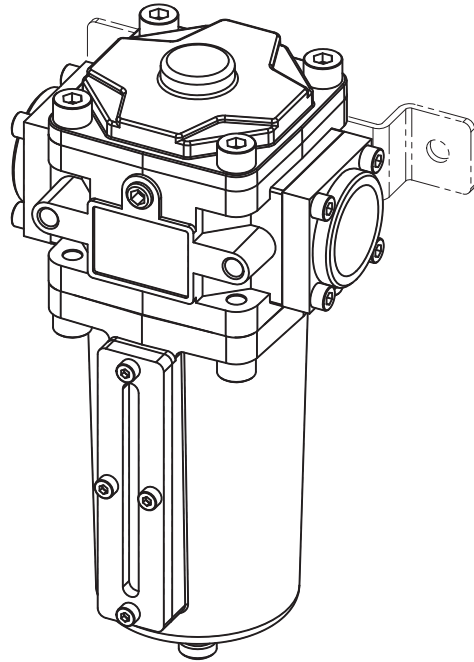

Construction Materials

- Body/bonnet/bowl and internals: 316L stainless steel
Note: on auto-drain version float is nylon, polyoxymethylene and rubber.
- Element: 40 micron sintered polypropylene (5 micron option available - suffix product code with '05')
- Seals: Standard option - Fluoroelastomer
Low temperature option - EPDM and Fluorosilicone¹

¹ The use of lubrication upstream of the product is not recommended for low temperature applications.

Accessories Available

- Mounting brackets

See page 27 for ordering details

Certification Options Available



3500 Series air service units – 3/4" to 1" Filters - Engineering Drawings (manual drain)

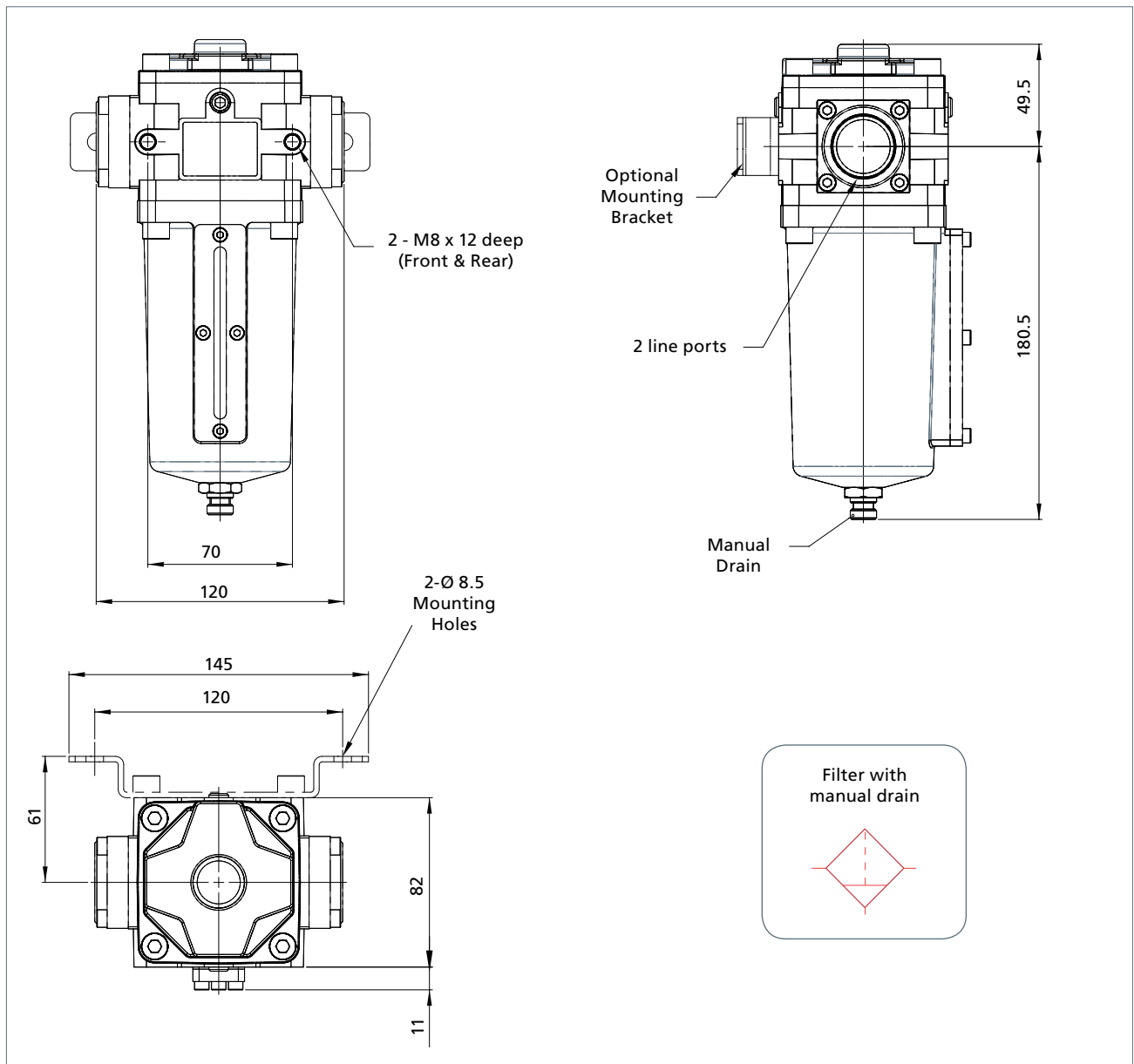

Size	Filter	Max Inlet Pressure bar	Weight kg	Cv
3/4"	Manual Drain	20	3.75	6.5
1"			3.75	8.8

3500 Series air service units – 3/4" to 1" Filters - Engineering Drawings (auto drain)

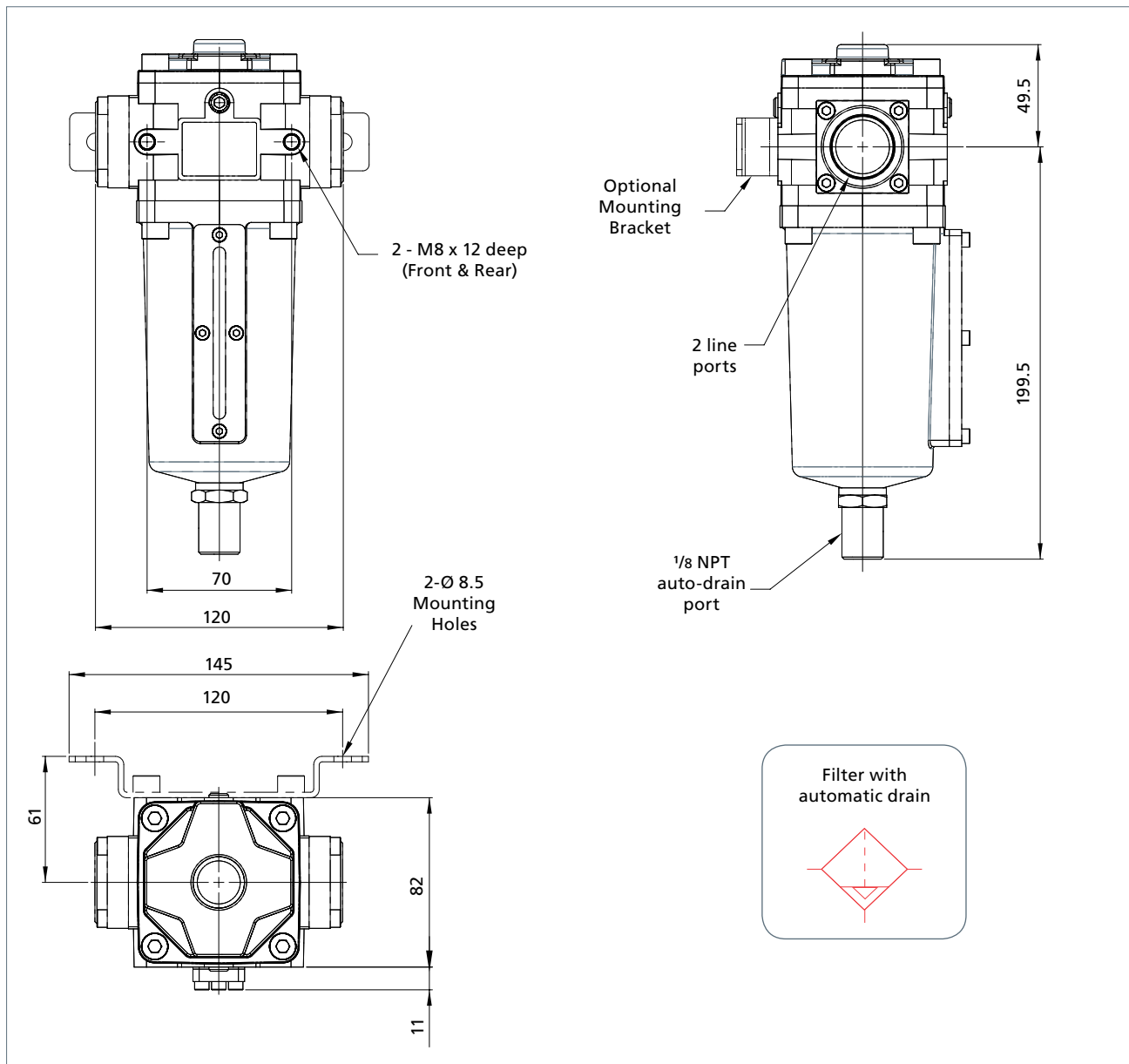

Size	Filter	Max Inlet Pressure bar	Weight kg	Cv
3/4"	Auto Drain	17	3.75	6.5
1"			3.75	8.8

3500 Series air service units – 3/4" to 1" Filters - Flow Characteristics

3500 Series Coding Chart - Filters

Additional Options

Size		Type		Material		Seals °C (°F)		Max Inlet Pressure bar (psi)		Port Style		Filter Element (40 micron standard)		Approval	
6	3/4"	FLM	Manual Drain	S	Stainless	V	Standard -20 (-4)	17	17 (247) (FLA only)	1	BSP	05	5 micron	/ATEX	II 2G c T6
8	1"	FLA	Auto Drain			L ¹	Low Temp -50 (-58)	20	20 (290) (FLM only)	2	NPT		w/o option		w/o option

•	•	S	•	•	•	•	•
---	---	---	---	---	---	---	---

¹ Low temperature version not available in auto-drain

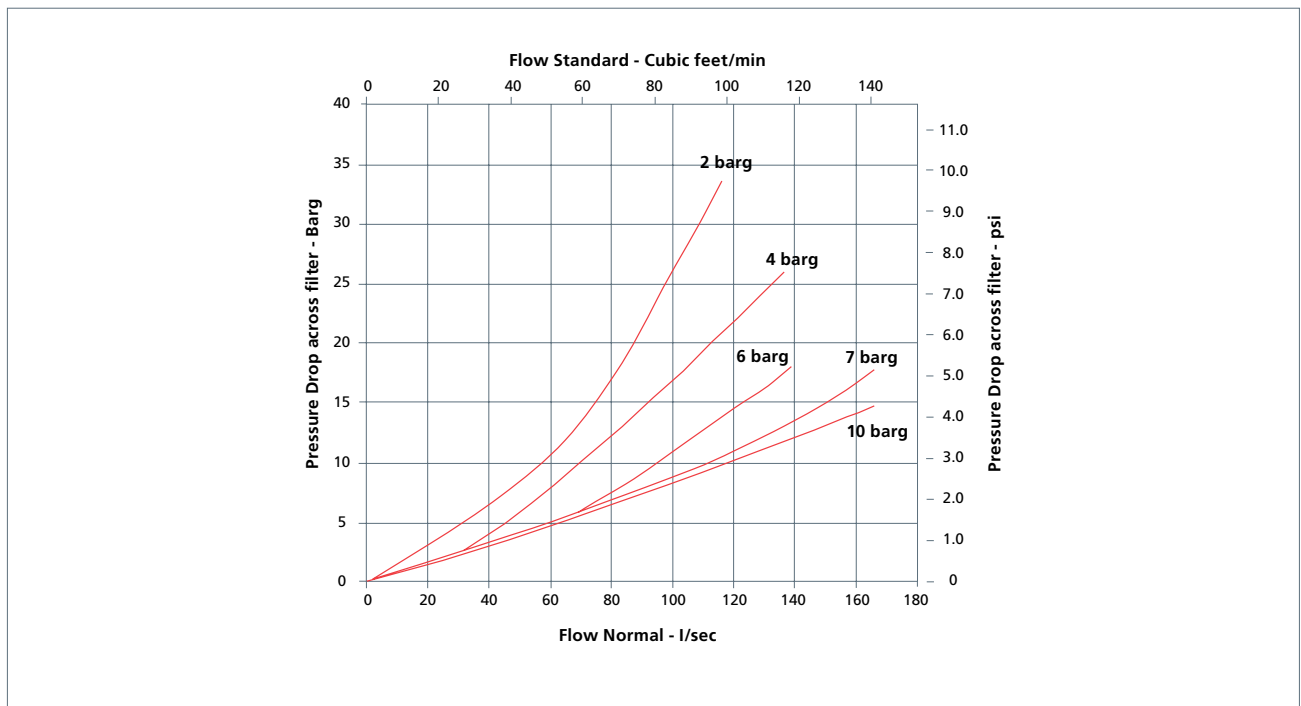

3500 Series air service units – 3/4" to 1" Pressure Regulators

A 316L stainless steel unit for pressure regulation of compressed air and gases for the actuation industries.

Features and Benefits

- Specifically designed for severe environments
- Non or self-relieving
- 316L stainless steel construction
- Large flow characteristics

Media & Ambient Temperature Range

- Standard temperature
-20 to + 80 °C (-4 to +176 °F)
- Low temperature version
-50 to +80 °C (-58 to +176 °F)

Note: When product is ordered as /ATEX ambient temperature is limited to +40°C (104 °F) Ex II 2G c T6.

Maximum Relief Flow

- At 2 bar (29 psi) secondary pressure
0.5 cc/sec (0.03 cu in/sec)

Flow

At 7 bar (102 psi) supply pressure, 6 bar (87 psi) secondary pressure, 1 bar (14.5 psi) pressure drop.

- 7,800 l/min (274 SCFM)

Ports NPT

(BSP option available - consult factory for part codes)

- 3/4", 1"

Gauge Ports

- 1/8" NPT

Relief Vent Port

- 1/8" NPT (fitted with breather)

Note: Not fitted on low temperature option

Size	Regulated Pressure bar (psi)	Max Inlet Pressure bar	Weight kg	Cv
3/4"	0.50 to 2.0 (7.2 to 29)	20	5.0	6.5
1"			5.0	8.8
3/4"	0.50 to 4.0 (7.2 to 58)	20	5.0	6.5
1"			5.0	8.8
3/4"	0.50 to 7.0 (7.2 to 102)	20	5.0	6.5
1"			5.0	8.8
3/4"	0.50 to 10.0 (7.2 to 145)	20	5.0	6.5
1"			5.0	8.8

Certification Options Available

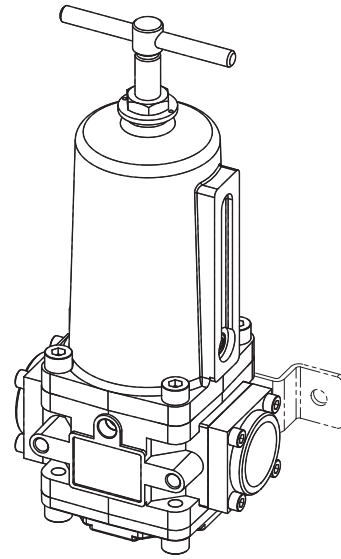

Operating Media

- Gases - air, inert gas, sweet (natural) gas

Note: To prevent freezing of the condensate within the product, the media dew point must be at least 10 °C below the lowest ambient temperature the product will be exposed to

Construction Materials

- Body/bonnet/bowl and internals: 316L stainless steel
- Seals: Standard option - Fluoroelastomer
Low temperature option - EPDM and Fluorosilicone¹

¹ The use of lubrication upstream of the product is not recommended for low temperature applications

Accessories Available

- Mounting brackets
- Stainless steel pressure gauge

See page 26-28 for ordering details

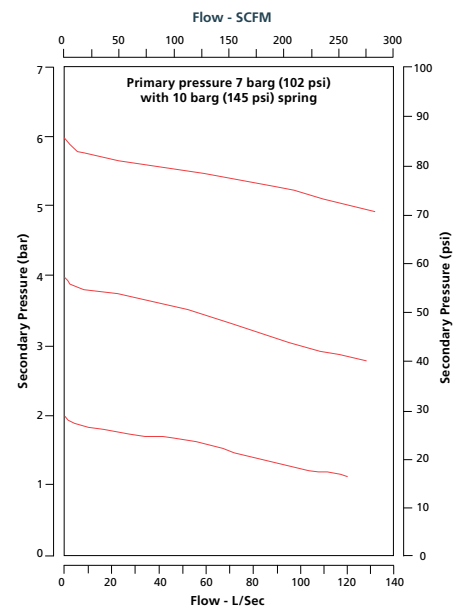

3500 Series air service units – 3/4" to 1" Pressure Regulators - Engineering Drawings

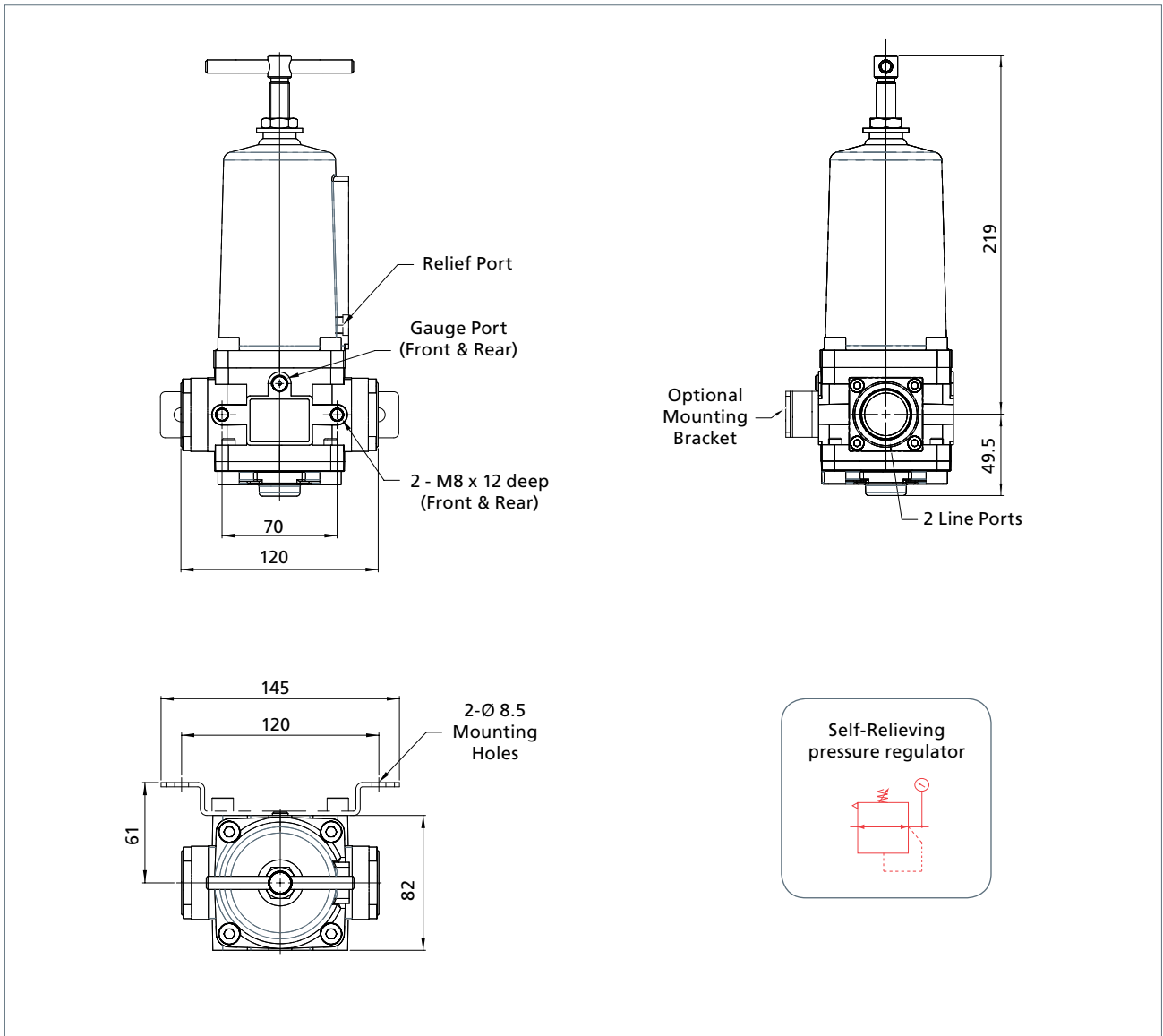

3500 Series Coding Chart - Pressure Regulators

Additional Option

Size		Type		Material		Seals °C (°F)		Regulated Pressure bar (psi)		Port Style		Approval	
6	3/4"	PRV	Self Relieving	S	Stainless	V	Standard -20 (-4)	02	2 (29)	1	BSP	/ATEX	Ex II 2G c T6
8	1"	PRN	Non Relieving			L	Low Temp -50 (-58)	04	4 (58)	2	NPT		w/o option
								07	7 (102)				
								10	10 (145)				
				S									

3500 Series air service units – 1/2" Lubricator

A 316L stainless steel unit providing lubrication of compressed air for the actuation industries.

Features and Benefits

- Specifically designed for severe environments
- Accurate drip rate adjustment
- Can be filled under pressure
- Transparent sight feed dome
- 316L stainless steel construction
- Built in flow sensor to automatically adjust lubrication delivery to meet wide air flow demand

Media & Ambient Temperature Range

- -20 to + 80 °C (-4 to +176 °F)

Note: When product is ordered as /ATEX ambient temperature is limited to +40 °C (104 °F) Ex II 2G c T6

Working Pressure

- 17 bar (247 psi)

Ports NPT

(BSP option available - consult factory for part codes)

- 1/2" NPT

Bowl Capacity

- 380 cc (23.2 cu ins)

Operating Media

- Gases - air, inert gas and sweet (natural) gases

Note: To prevent freezing of the condensate within the product, the media dew point must be at least 10 °C below the lowest ambient temperature the product will be exposed to.

Construction Materials

- Body/bonnet/bowl and internals: stainless steel 316L
- Seals: Nitrile
- Bowl: 316 stainless steel
- Acrylic flow and sight glass

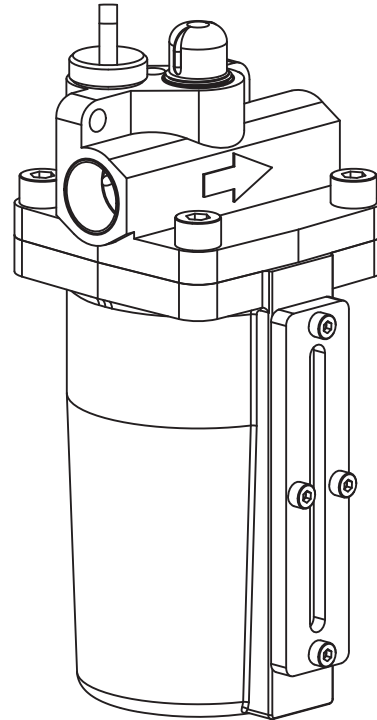

3500 Series air service units – 1/2" Lubricator - Engineering Drawings

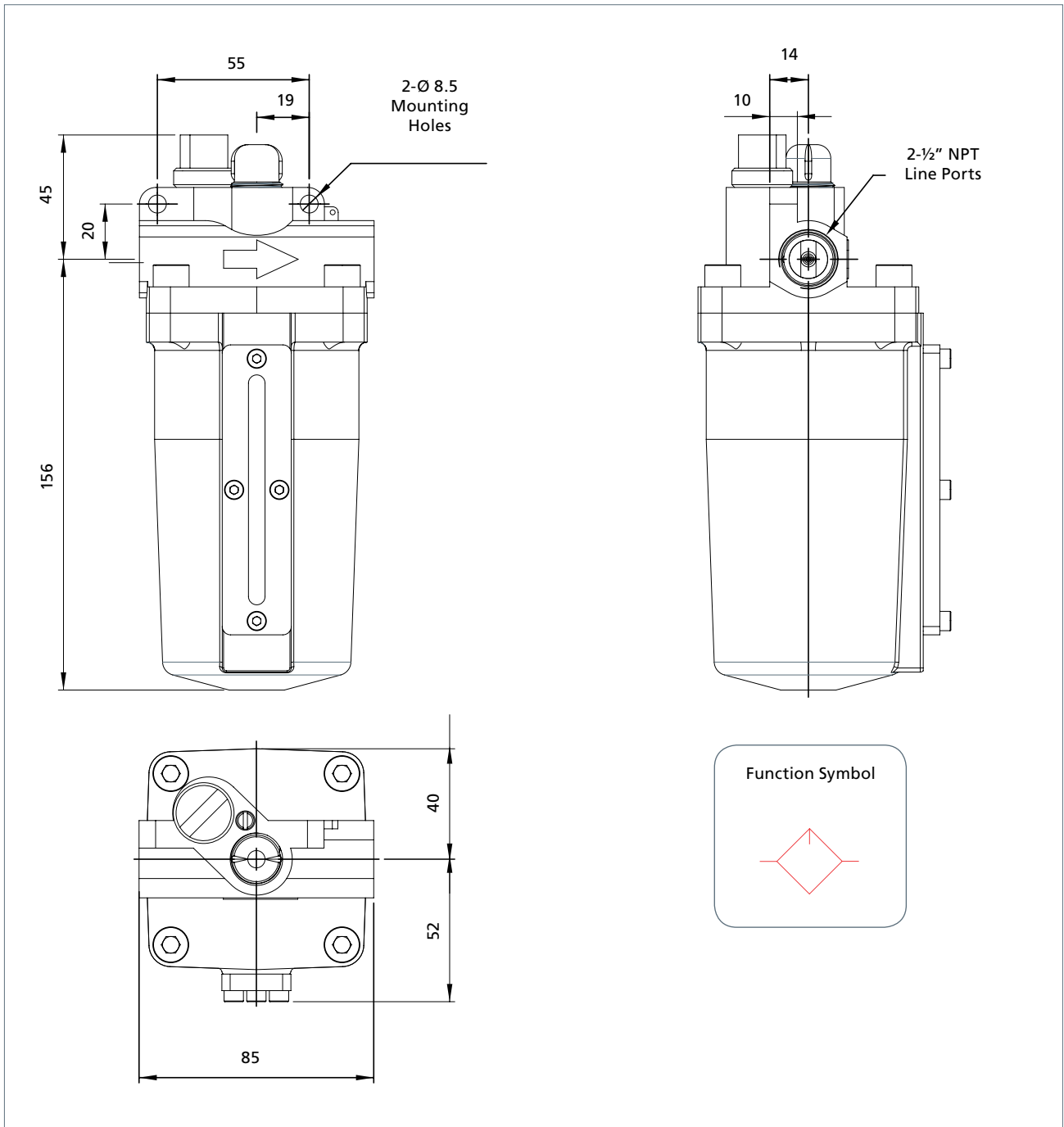

3500 Series Coding Chart - Lubricator

Size		Type		Material		Seals		Pressure bar (psi)		Port Style	
4	1/2"	LUB	LUB	S	Stainless	N	Nitrile	17	17 (246)	2	NPT
4		LUB		S		N		17		2	

3500 Series air service units – Accessories for 3/4" to 1" units - supplied separately

Pressure gauge SS-316L - Glycerine filled

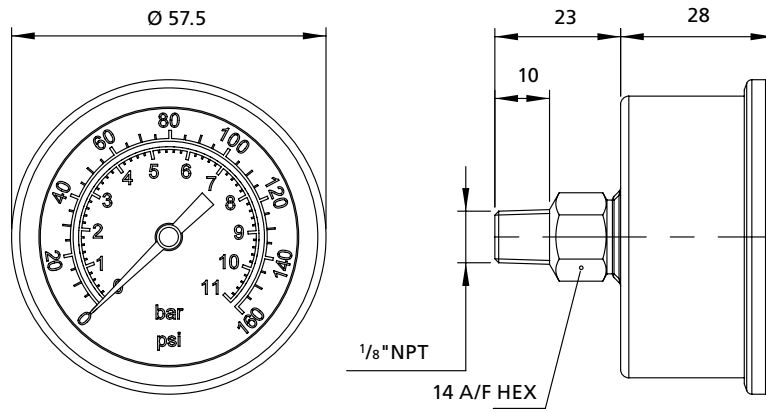

Product Code	Size mm	Regulated Pressure bar
SSF153N/2GLY	50	0 to 2
SSF153N/4GLY	50	0 to 4
SSF153N/11GLY	50	0 to 11

Please consult factory for low temperature version if required.

Tamperproof cap kit

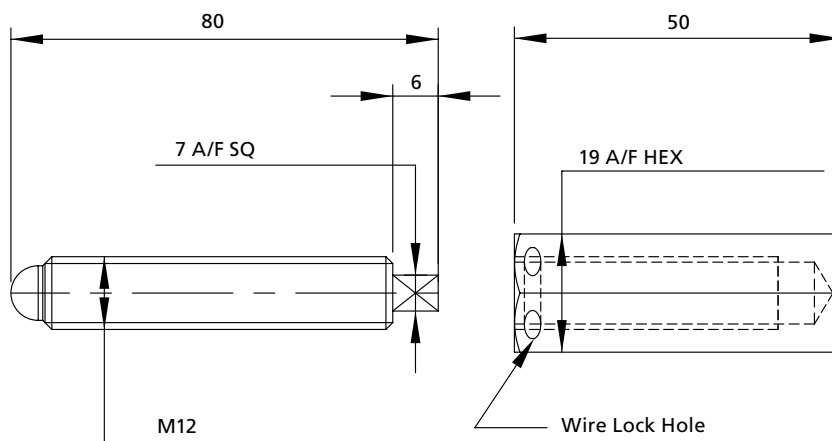

Product Code	Description
SSAF638/22	Kit comprises of 1 pressure adjusting screw and 1 tamperproof cap. All material stainless steel

3500 Series air service units – Accessories for 3/4" to 1" units - supplied separately

Mounting bracket

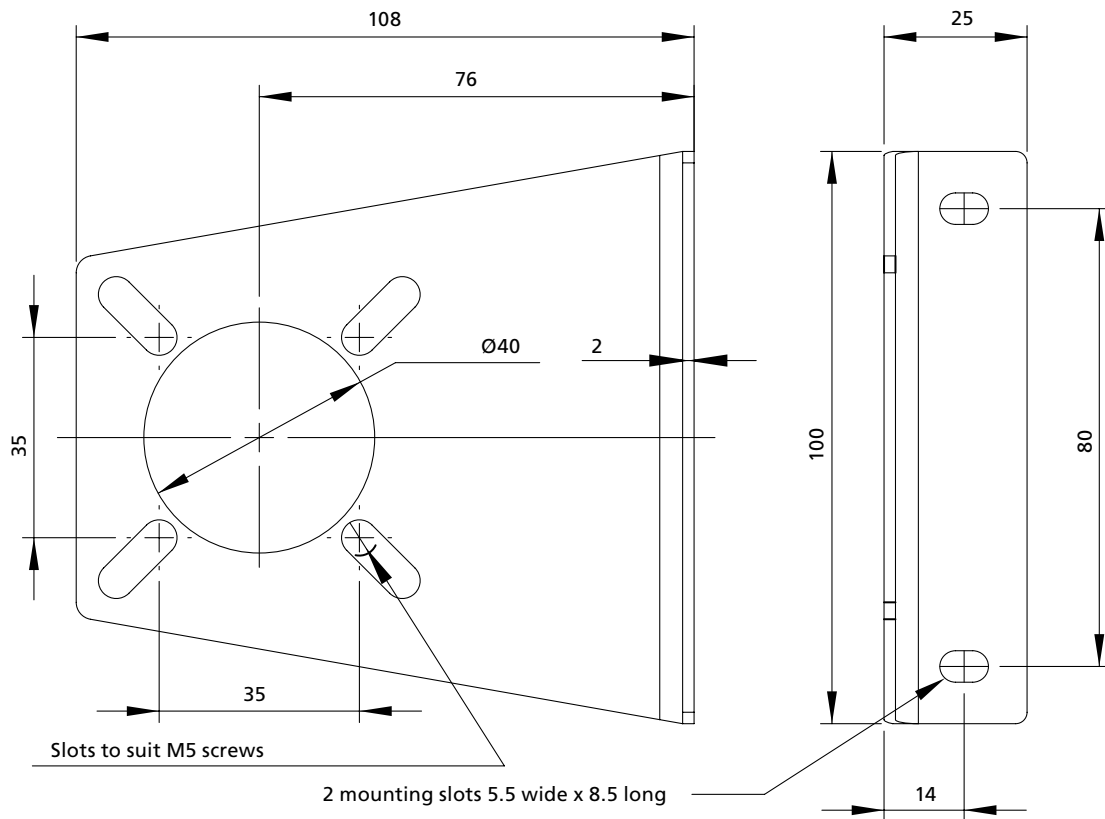

Filter / Regulator with Mounting Brackets

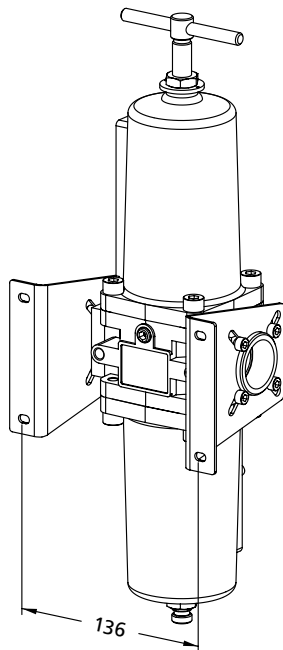

Product Code	Suitable for
SSF8110-7	3/4" & 1" units

Component material 316 stainless steel.
 Brackets are supplied complete with fasteners.
Note: Part number above is for single item.

3500 Series air service units – Accessories for 3/4" to 1" units - supplied separately

Rear mounting bracket

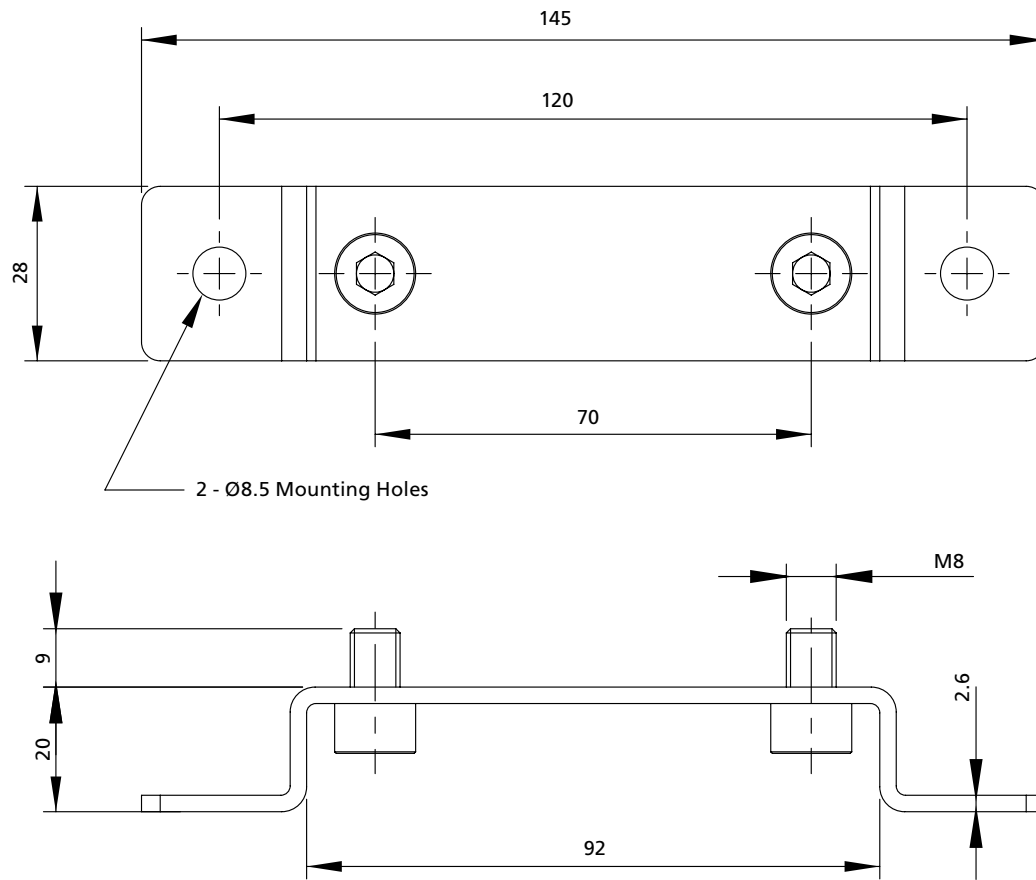

Filter / Regulator with Rear Bracket

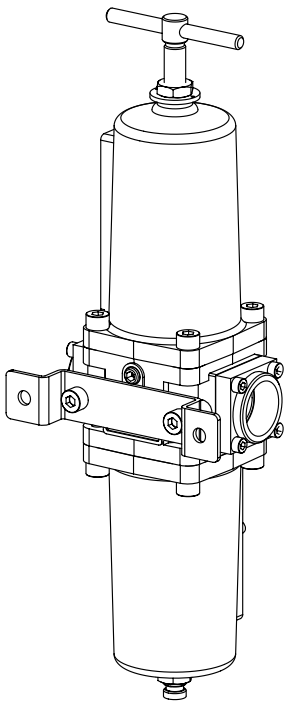

Product Code	Description
SSAF638-26	Kit comprises of 1 mounting bracket and 2 - M8 x12 cap head screws. All material stainless steel.

3575 Series air service units – 1½" to 2" Filter Regulators

A 316L stainless steel combined unit for filtration and regulation of compressed air and gases for the actuation industries.

Features and Benefits

- Specifically designed for severe environments
- Self-relieving
- Manual or auto-drain
- 25 micron element stainless steel 316
- 316L stainless steel construction
- Mounting brackets supplied fitted as standard
- Gauge supplied fitted as standard
- Regulated pressure range from 0.50 to 12.0 bar depending on model selection
- Option available to supply without pilot regulator (consult factory for product code)
- Large flow paths (up to 45 Cv)
- NACE capability option available, manual drain only (consult factory)

Units ordered with a specified pressure range will be supplied complete with a pilot regulator and piped using double ferrule fittings.

Media & Ambient Temperature Range

- Standard temperature
-20 to +80 °C (-4 to +176 °F)
- Low temperature version
-50 to +80 °C (-58 to +176 °F)

Ports NPT

(BSP option available - consult factory for part codes)

- 1½", 2"

Gauge Ports

- 1/8" NPT (fitted with gauge)

Relief Vent Port

- 1/2" NPT (fitted with breather)

Maximum Relief Flow

- At 2 bar (29 psi) secondary pressure
0.5 cc/sec (0.03 cu in/sec)



Flow

At 10 bar (145 psi) supply pressure, 6 bar (87 psi) secondary pressure, 1 bar (14.5 psi) pressure drop.

- 2" - 45,000 l/min (1,590 SCFM)

Bowl Capacity

- 21 cc (1.28 cu ins)

Operating Media

- Air, inert gas and sweet (natural) gas
- Sour gas (NACE) manual drain only

Note: To prevent freezing of the condensate within the product, the media dew point must be at least 10 °C below the lowest ambient temperature the product will be exposed to.

Construction Materials

- Body/bonnet/bowl and internals: 316L stainless steel
Note: on auto-drain version float is nylon, polyoxymethylene and rubber.
- Element: 25 micron 316 stainless steel
- Seals: Nitrile

3575 Series air service units – 1½" to 2" Filter Regulators - Engineering Drawings

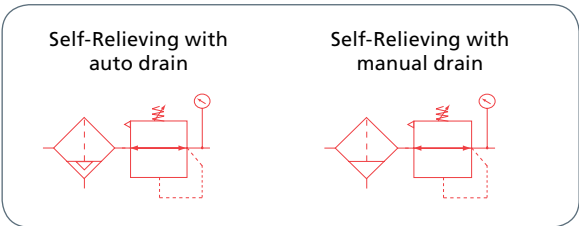
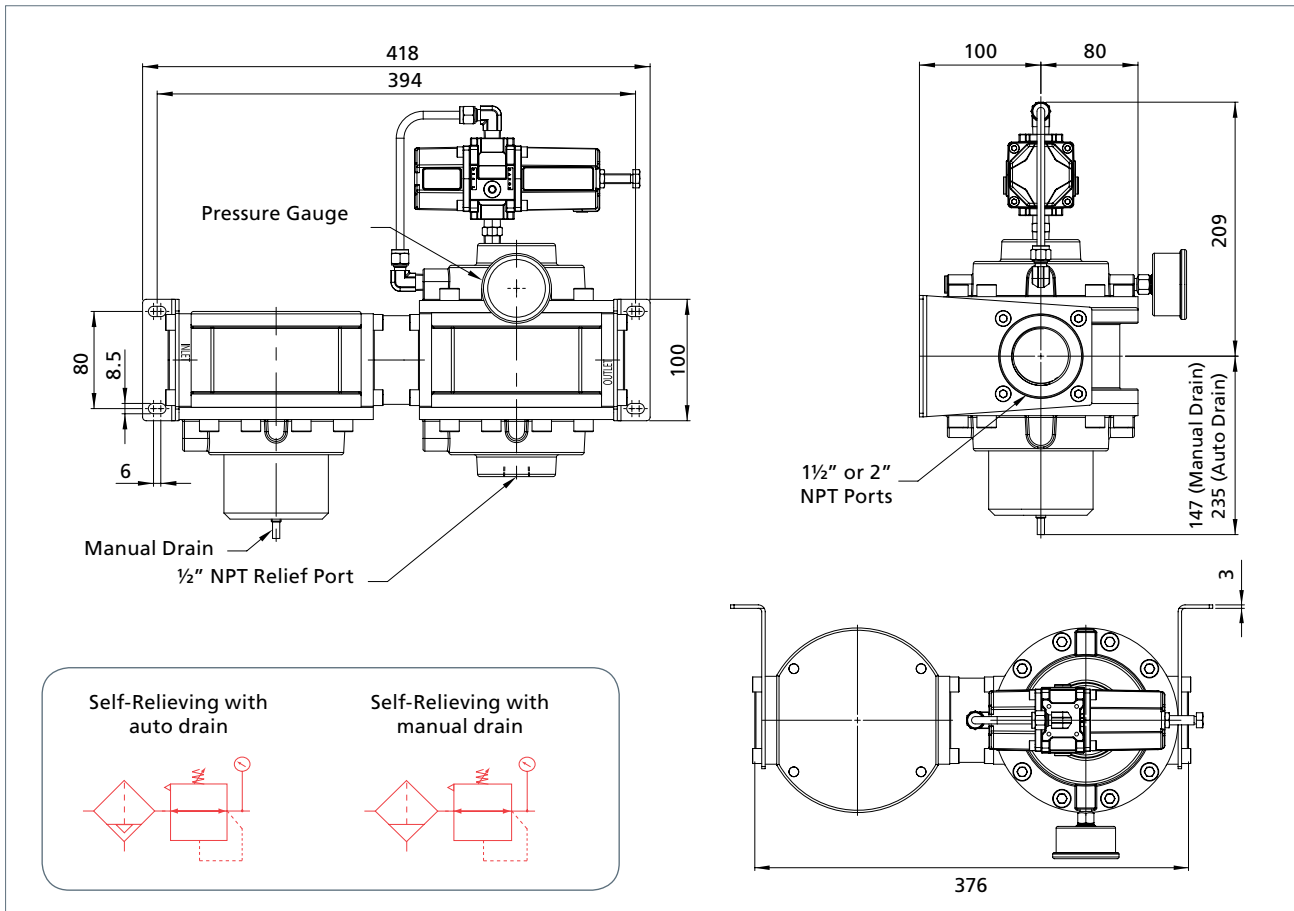

Size	Filter	Regulated Pressure bar (psi)	Max Inlet Pressure bar	Weight kg	Cv		
1½"	Manual Drain	0.50 to 2.0 (7.2 to 29)	20	19	38		
2"					45		
1½"	Auto Drain		17		38		
2"					45		
1½"	Manual Drain		0.50 to 4.0 (7.2 to 58)		20	19	38
2"							45
1½"	Auto Drain	17		38			
2"				45			
1½"	Manual Drain	0.50 to 8.0 (7.2 to 116)		20	19		38
2"							45
1½"	Auto Drain		17	38			
2"				45			
1½"	Manual Drain		0.50 to 12.0 (7.2 to 174)	20		19	38
2"							45
1½"	Auto Drain	17		38			
2"				45			

3575 Series Coding Chart - Filter Regulators

Size		Type		Material		Seals °C (°F)		Regulated Pressure bar (psi)		Port Style	
7	1½"	FRM	Manual Drain	S	Stainless	N	Standard -20 (-4)	02	2 (29)	1	BSP
9	2"	FRA	Auto Drain			L ¹	Low Temp -50 (-58)	04	4 (58)	2	NPT
								08	8 (116)		
								12	12 (174)		

1 – Low temperature version not available in auto-drain

3575 Series air service units – 1½” to 2” Filters

A 316L stainless steel compressed air filter, designed to provide clean air for the actuation industries.

Features and Benefits

- Specifically designed for severe environments
- Manual or auto-drain
- 25 micron element stainless steel 316
- 316L stainless steel construction
- Mounting brackets supplied fitted as standard
- Large flow paths (up to 45 Cv)
- NACE capability option available, manual drain only (consult factory)

Media & Ambient Temperature Range

- Standard temperature
-20 to + 80 °C (-4 to +176 °F)
- Low temperature version
-50 to +80 °C (-58 to +176 °F)

Ports NPT

(BSP option available - consult factory for part codes)

- 1½”, 2”

Flow

At 6 bar (87 psi) supply pressure, 1 bar (14.5 psi) pressure drop.

- 2” - 45,000 l/min (1,590 SCFM)

Bowl Capacity

- 21 cc (1.28 cu ins)

Operating Media

- Air, inert gas and sweet (natural) gas
- Sour gas (NACE) manual drain only

Note: To prevent freezing of the condensate within the product, the media dew point must be at least 10 °C below the lowest ambient temperature the product will be exposed to.



Construction Materials

- Body/bonnet/bowl and internals: 316L stainless steel
Note: on auto-drain version float is nylon, polyoxymethylene and rubber.
- Element: 25 micron 316 stainless steel
- Seals: Nitrile

Size	Filter	Max Inlet Pressure bar	Weight kg	Cv
1½”	Manual Drain	20	8.7	38
2”			8.7	45
1½”	Auto Drain	17	8.7	38
2”			8.7	45

3575 Series air service units – 1½" to 2" Filters - Engineering Drawings

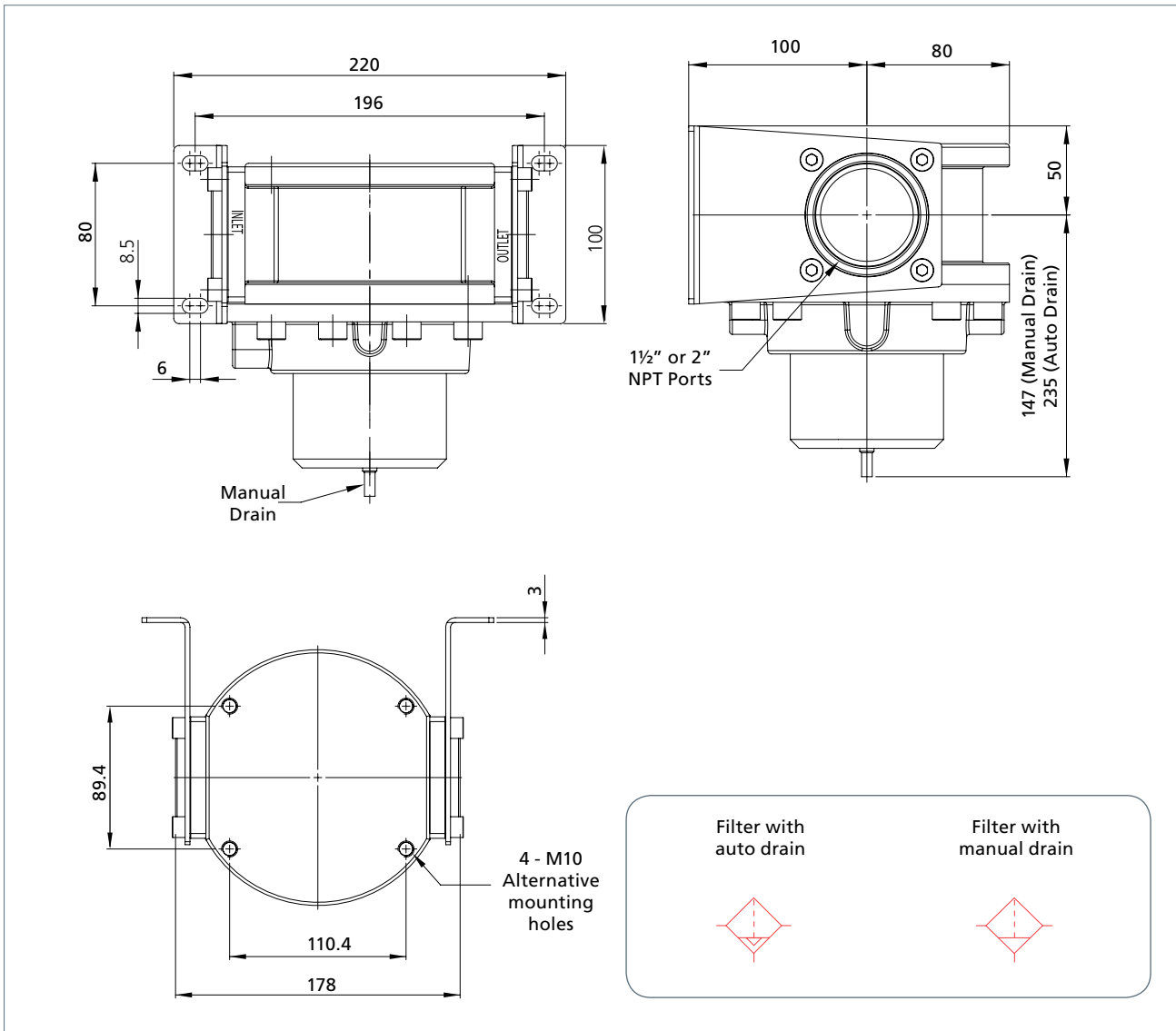

3575 Series Coding Chart - Filters

Size		Type		Material		Seals °C (°F)		Max Inlet Pressure bar (psi)		Port Style	
7	1 ½"	FLM	Manual Drain	S	Stainless	N	Standard -20 (-4)	17	17 (247) (FLA only)	1	BSP
9	2"	FLA	Auto Drain			L ¹	Low Temp -50 (-58)	20	20 (290) (FLM only)	2	NPT

●	●	S	●	●	●
---	---	---	---	---	---

1 – Low temperature version not available in auto-drain

3575 Series air service units – 1½" to 2" Pressure Regulators

A 316L stainless steel unit for pressure regulation of compressed air and gases for the actuation industries.

Features and Benefits

- Specifically designed for severe environments
- Self-relieving
- 316L stainless steel construction
- Mounting brackets supplied fitted as standard
- Gauge fitted as standard
- Regulated pressure range from 0.50 to 12.0 bar depending on model selection
- Large flow paths (up to 45 Cv)
- Option available to supply without pilot regulator (consult factory for product code)
- NACE capability option available (consult factory)

Units ordered with a specified pressure range will be supplied complete with a pilot regulator piped using double ferrule fittings.

Media & Ambient Temperature Range

- Standard temperature
-20 to +80 °C (-4 to +176 °F)
- Low temperature version
-50 to +80 °C (-58 to +176 °F)

Ports NPT

(BSP option available - consult factory for part codes)

- 1½", 2"

Gauge Ports

- 1/8" NPT (fitted with gauge)

Relief Vent Port

- 1/2" NPT (fitted with breather)

Maximum Relief Flow

- At 2 bar (29 psi) secondary pressure
0.5 cc/sec (0.03 cu in/sec)



Flow

At 10 bar (145 psi) supply pressure, 6 bar (87 psi) secondary pressure, 1 bar (14.5 psi) pressure drop.

- 2" - 45,000 l/min (1,590 SCFM)

Operating Media

- Air, inert gas and sweet (natural) gas
- Sour gas (NACE) manual drain only

Note: To prevent freezing of the condensate within the product, the media dew point must be at least 10 °C below the lowest ambient temperature the product will be exposed to.

Construction Materials

- Body/bonnet/bowl and internals: 316L stainless steel
Note: on auto-drain version float is nylon, polyoxymethylene and rubber.
- Seals: Nitrile

Size	Regulated Pressure	Max Inlet Pressure bar	Weight kg	Cv
1½"	0.50 to 2.0 bar (7.2 to 29 psi)	20	11	38
2"				45
1½"	0.50 to 4.0 bar (7.2 to 58 psi)			38
2"				45
1½"	0.50 to 8.0 bar (7.2 to 116 psi)			38
2"				45
1½"	0.50 to 12.0 bar (7.2 to 174 psi)			38
2"				45

3575 Series air service units – 1½" to 2" Pressure Regulators - Engineering Drawings

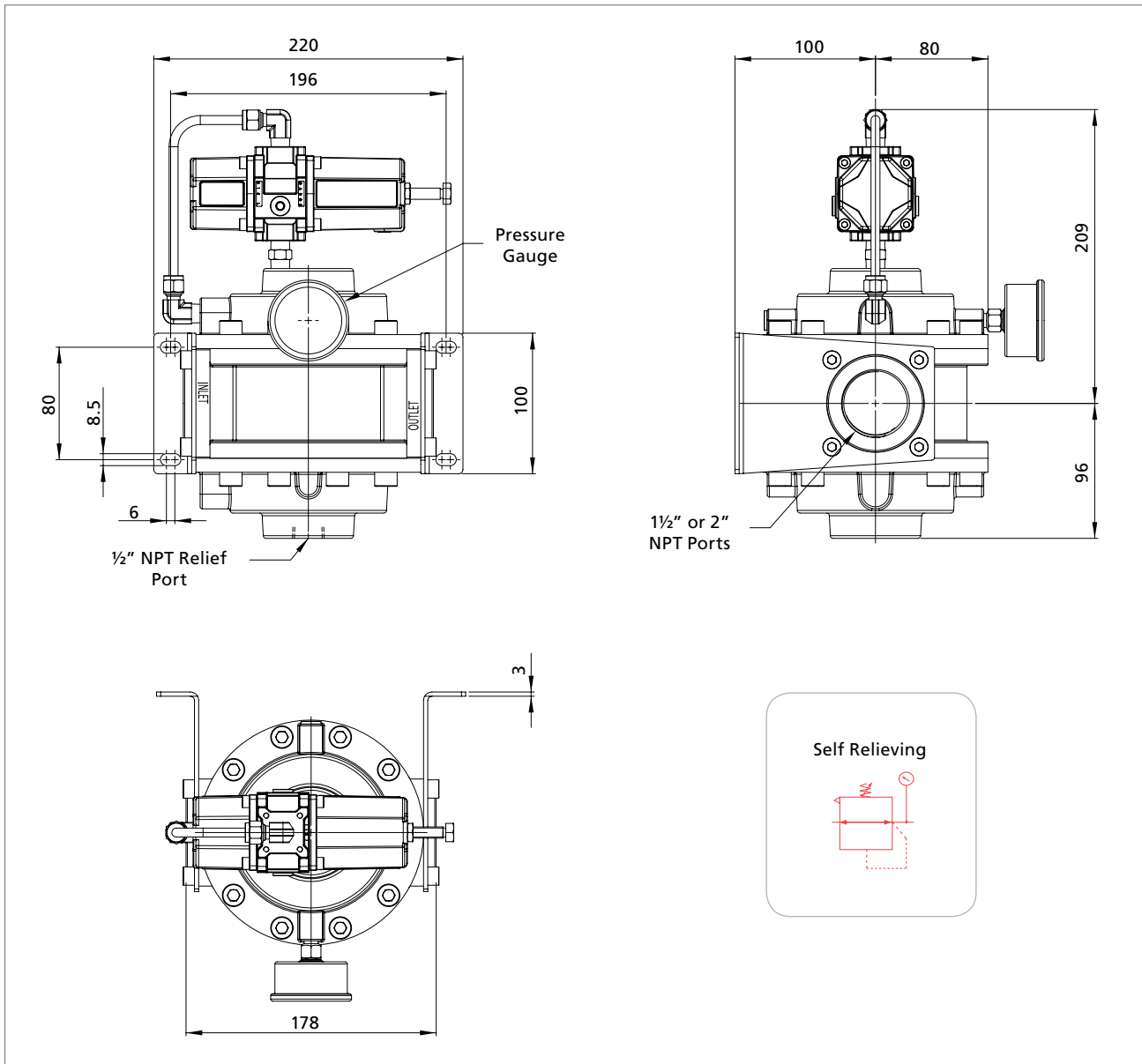

3575 Series Coding Chart - Pressure Regulators

Size		Type		Material		Seals °C (°F)		Regulated Pressure bar (psi)		Port Style	
7	1 ½"	PRV	Self Relieving	S	Stainless	N	Standard -20 (-4)	02	2 (29)	1	BSP
9	2"					L	Low Temp -50 (-58)	04	4 (58)	2	NPT
								08	8 (116)		
								12	12 (174)		

Over Pressurisation Device – OPD

A 316L stainless steel unit providing protection to downstream equipment from over pressure events.

Features and Benefits

- Protection of equipment from regulator failure and over pressure events
- Specifically designed for severe environments
- Manifold mounted option
- Auto shut-off
- ¼ turn actuator and on/off valve protection
- Linear actuator and control valve protection
- System instrumentation equipment protection
- Process valve stem & seat saver
- Easy installation
- 316L stainless steel construction
- Compliments and protects ESD & safety instrumented system equipment

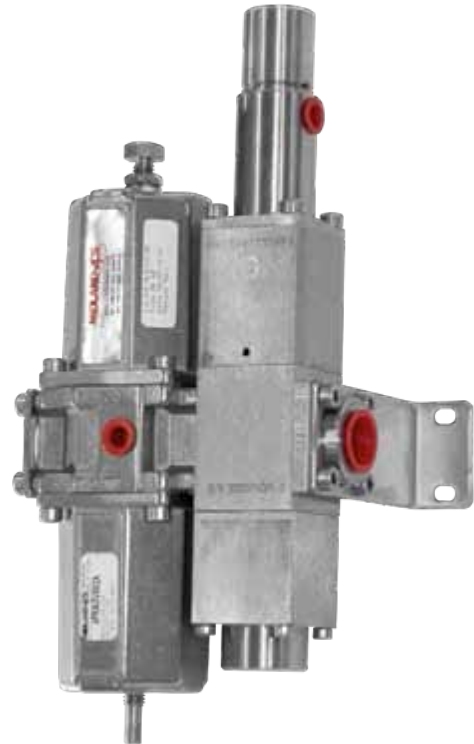

Regulated outlet pressure range

- 4 - 8 bar

Trip Pressure Range

- 4.5 - 8.5 bar (4-8 bar)

Maximum Response Time

- 30 ms (4-8 bar)

Temperature Range

- Standard: -20 to +80 °C (-4 to +176 °F)
- Low temp: -50 to +80 °C (-58 to +176 °F) optional

Maximum Inlet Pressure

- Manual drain: 20 bar
- Auto drain: 17 bar

Coding Chart - OPD

Size		Type		Material		Seals		PRV Pressure Range bar (psi) 4 - 8 (58 - 116)		Port Style		Function		Secondary Pressure ¹		Trip Pressure ²		Revision
4	½"	OPD	Manual Drain	S	Stainless	V	Viton	-	Rotork Midland to specify via customer set & trip pressure	1	BSP	3	3/2	-	Customer specified	-	Customer specified	A
		OPA	Auto Drain							2	NPT			XX	Unset	XX	Unset	
4		•		S		V		•		•		3		•		•		A

¹ Use two digits to specify set pressure, e.g. 49 = 4.9 bar. Must be within the PRV pressure range of 4 - 8 bar

² Use two digits to specify trip pressure, e.g. 54 = 5.4 bar. Must be at least 0.5 bar above SECONDARY pressure but not more than 0.5 bar above the maximum PRV pressure range for the variant selected.

Over Pressurisation Device – OPD

General Description

The purpose of the OPD is to protect downstream equipment from over pressure events including regulator failure, thus preventing potential damage and downtime. Applications include the protection of ESD & Safety Instrumented Systems including positioners, actuators and process valve stems. The device includes a pressure regulator with a protection valve and sensor system.

Increases in outlet pressure can occur for many reasons, including failure of key regulator components or misadjustment. Should this occur the device will automatically fail-safe within 30 milli-seconds. The protection valve will be triggered to shut-off the outlet and vent the downstream pressure.

When the protection valve has deployed, the reset button protrudes from the housing providing a positive indication that a fault has occurred. The OPD reduces the potential for damage occurring from increased torque, thrust or pressure values within the downstream system. Once the fault has been corrected the unit can be reset by pushing the reset button on the unit. In line with today's requirements for space saving, weight reduction and efficiency the system is all close coupled within a compact body.



Development

Failures of pressure regulators can result in the over pressurisation of the downstream line, as the self-relieving capacity of the regulator is insufficient to cope with major failures. Usually a relief valve of sufficient capacity is fitted into the system to hold the pressure down to an acceptable level.

However a relief valve flow is sized on a pressure differential between set pressure and over pressure, usually 10%. Thus on a set pressure of 4.5 barg a pressure rise to 4.95 barg would have to flow sufficiently to hold the pressure at 4.95 barg, against the flow through a failed pressure regulator. At 10 barg supply pressure the flow through the failed pressure regulators will be driven by a 10 to 4.95 i.e. 5.05 barg pressure drop. In many cases this would result in damage to sensitive & expensive equipment such as positioners, actuator diaphragms and process valve stems. An alternative is to fit an excessively large relief valve(s), which in itself could cause serious problems by dumping all of the systems air and starving other equipment resulting in plant shutdown and potential compressor damage.

Considered Regulator Failure modes

Failure modes are common to all manufacturers' regulators unless specific design changes have been made to cope with them. Therefore to overcome these difficulties the Over Pressurisation Device was designed and engineered.

Typical Regulator Failure Modes

- Misuse and maladjustment during installation and commissioning.
- Rupture of diaphragm leading to total loss of pressure regulation.
- Failure of regulator seat leading to partial or total loss of pressure regulation.
- Blocking of the regulator relief port leading to total loss of pressure regulation.



Over Pressurisation Device – OPD

Performance Characteristics

Response times are dependant upon the actual pressures within the system at the point of failure; all times stated within the specification section are maximums taken at the lowest extreme of the pressure range (worst case).

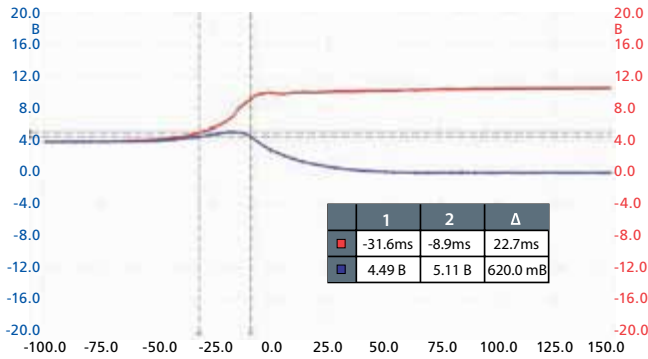

The magnitude of any pressure spikes exceeding the trip pressure which occur during deployment of the valve are dependant upon the system downstream volume; a larger system volume decreases the likelihood of the system pressure exceeding the trip pressure (see graphs). Any pressure spikes which do occur will only do so for a fraction of a second (less than the time taken for the device to operate).

Small actuator test results.

- 4-8 bar OPD; outlet connected to a volume of 0.2 litres

Trigger Test:

- **Blue** = Simulated actuator pressure (bar)
- **Red** = Supply pressure (bar)

The graph to the left is an overpressure test result with a small 0.2 litre reservoir to simulate the actuator. An overpressure signal is applied allowing the 11 barg supply pressure to bypass the regulator, simulating a ruptured diaphragm. The response time of the device is measured as the time between the pressure within the device reaching the trip pressure and the actuator pressure returning to below the regulated pressure (see dashed lines on graph & right hand column of table).

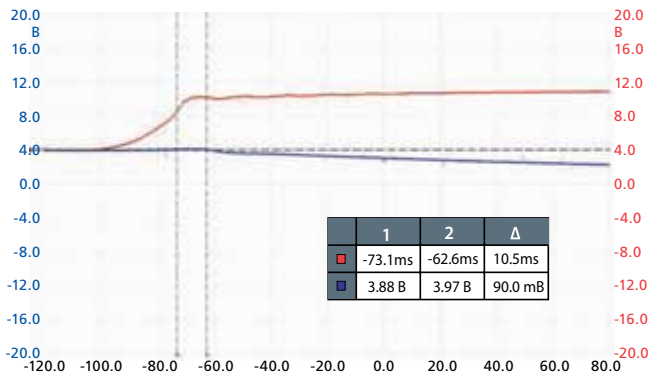

Larger actuator test results.

- 4-8 bar OPD; outlet connected to a volume of 3 litres

Trigger Test:

- **Blue** = Actuator pressure (bar)
- **Red** = Supply pressure (bar)

The graph above is an overpressure test result with a larger 3 litre reservoir to simulate the actuator. An overpressure signal is applied allowing the 11 barg supply pressure to bypass the regulator, simulating a ruptured diaphragm. The response time of the device is measured as the time between the pressure within the device reaching the trip pressure and the actuator pressure returning to below the regulated pressure (see dashed lines on graph & right hand column of table).

Note: During this test the actuator pressure does not exceed the trip pressure value.

Test Circuit

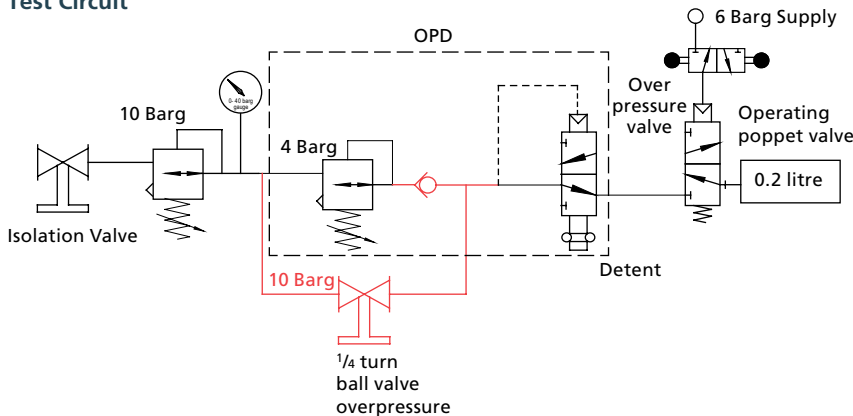

Over Pressurisation Device – OPD - Engineering Drawings

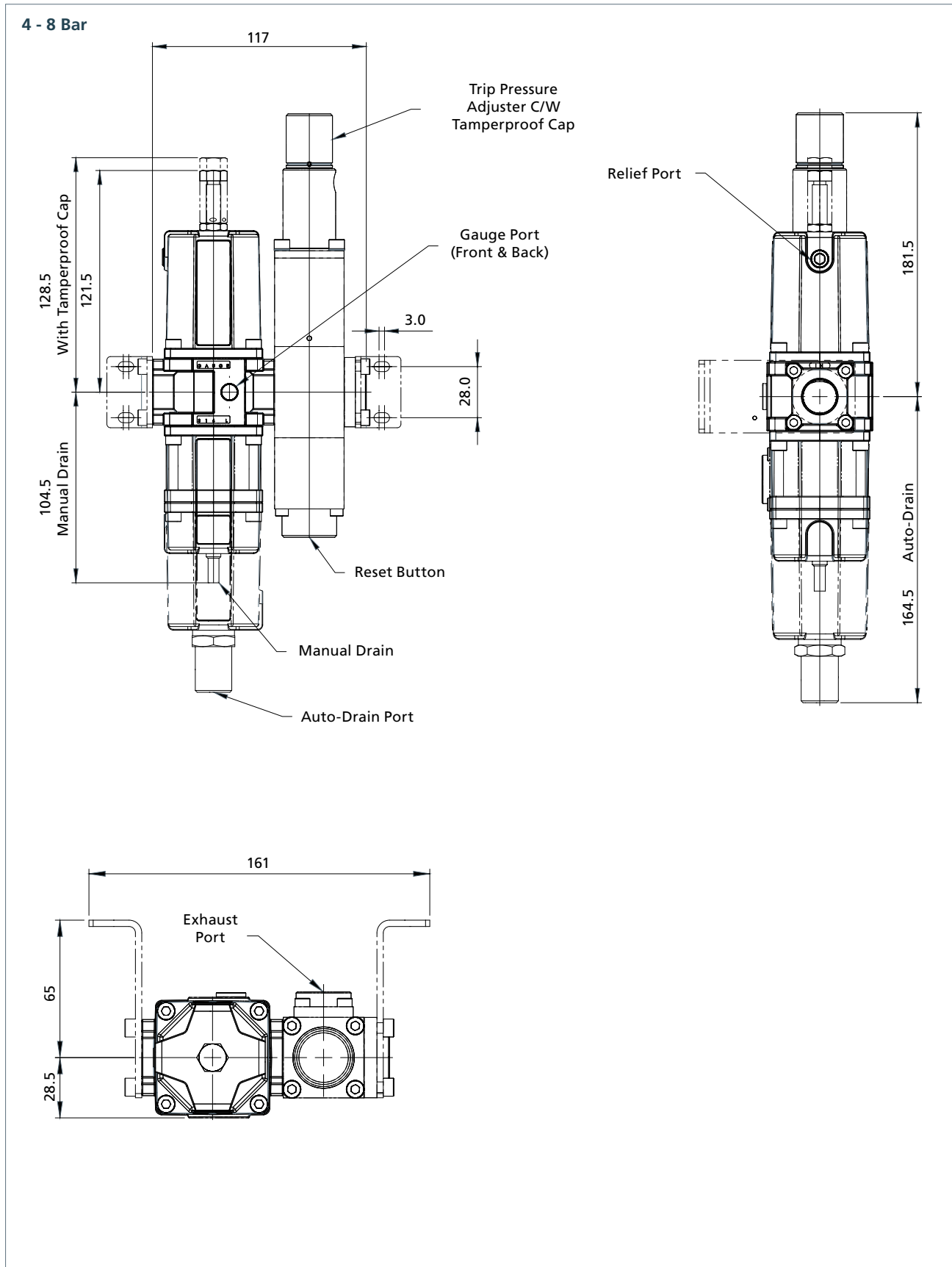

Oil & Gas industries

MIDLAND-ACS
A rotork® Brand

Since our founding in 1956, we have been known internationally as one of the oil & gas industries premier designers and manufacturers of 316L stainless steel control equipment. Over the years we have developed an enviable reputation for high quality products, reliability and innovation.

We have the ability to investigate problems and provide comprehensive solutions for the control of hydraulic and pneumatic actuated process control valves across a broad range of industries and markets. This, coupled with repeatedly delivering impressive results worldwide, sets us apart from our competitors.



rotork®

Rotork are experts in flow control, pressure control, flow measurement and pressure measurement.

We manufacture products and components that are trusted for applications where high precision and reliability are required.

Rotork has manufacturing facilities in USA, Italy, Brazil, India, China and Singapore.

The Rotork global sales and service network supports all Rotork products. This network is the biggest global actuation support organisation in the world with direct sales offices and agents in all industrialised countries.

Customer service and field support provides quick and effective response to customer requirements.

The Rotork Site Services network is represented throughout the world and provides valuable service and assistance to all industries.



rotork®

Keeping the World Flowing



www.rotork.com

A full listing of our worldwide sales and service network is available on our website.

Rotork Midland Ltd.
Patrick Gregory Road
Wolverhampton
WV11 3DZ, UK
tel +44 (0)1902 305 678
email sales.midland@rotork.com

Rotork is a corporate member of the Institute of Asset Management



PUB117-001-00
Issue 07/19

As part of a process of on-going product development, Rotork reserves the right to amend and change specifications without prior notice. Published data may be subject to change. For the very latest version release, visit our website at www.rotork.com
The name Rotork is a registered trademark. Rotork recognises all registered trademarks. Published and produced in the UK by Rotork. Registered office: Rotork plc, Brassmill Lane, Bath, BA1 3JQ, UK. POWJB0619.